

Link-Belt®

CONSTRUCTION EQUIPMENT

RTC – 8030

CRANE RATING MANUAL

4-SECTION BOOM

20.5 X 25 TIRES

SERIAL NUMBER D3TC-5380

For Replacement, Order Part Number D3P0070.

RTC – 8030 4 – SECTION BOOM 20.5 X 25.0 TIRES

Page	Contents
3	Operating Instructions
5	General Dimensions
6	Winch Performance
6	Wire Rope Strength
7	Working Areas
7	Hydraulic Circuit Pressure Settings
7	Capacity Deductions
	Fully Extended Outriggers
9	Working Range Diagram
10	Lifting Capacities, Main Boom, 28.75–58 Ft. Manual Retracted
11	Lifting Capacities, Main Boom, 64–70.25 Ft. Manual Retracted
12	Lifting Capacities, Main Boom, 91 Ft. Manual Extended
13	Lifting Capacities, 25 Ft. Fixed Fly Manual Retracted
14	Lifting Capacities, 25 Ft. Fixed Fly Manual Extended
15	Lifting Capacities, 25 Ft. Offset Fly Manual Retracted
16	Lifting Capacities, 25 Ft. Offset Fly Manual Extended
17	Lifting Capacities, 25 Ft. Offset Telescoping Fly Manual Retracted
18	Lifting Capacities, 43 Ft. Offset Telescoping Fly Manual Retracted
19	Lifting Capacities, 25 Ft. Offset Telescoping Fly Manual Extended
20	Lifting Capacities, 43 Ft. Offset Telescoping Fly Manual Extended
	Half Extended Outriggers
21	Working Range Diagram
22	Lifting Capacities, Main Boom, 28.75–58 Ft. Manual Retracted
23	Lifting Capacities, Main Boom, 64–70.25 Ft. Manual Retracted
24	Lifting Capacities, Main Boom, 91 Ft. Manual Extended
25	Lifting Capacities, 25 Ft. Fixed Fly Manual Retracted
26	Lifting Capacities, 25 Ft. Fixed Fly Manual Extended
27	Lifting Capacities, 25 Ft. Offset Fly Manual Retracted
28	Lifting Capacities, 25 Ft. Offset Fly Manual Extended
29	Lifting Capacities, 25 Ft. Offset Telescoping Fly Manual Retracted
30	Lifting Capacities, 43 Ft. Offset Telescoping Fly Manual Retracted
31	Lifting Capacities, 25 Ft. Offset Telescoping Fly Manual Extended
32	Lifting Capacities, 43 Ft. Offset Telescoping Fly Manual Extended
	Fully Retracted Outriggers
33	Working Range Diagram
34	Lifting Capacities, Main Boom, 28.75–58 Ft. Manual Retracted
35	Lifting Capacities, Main Boom, 64–70.25 Ft. Manual Retracted
36	Lifting Capacities, Main Boom, 91 Ft. Manual Extended
	On Tires
37	Lifting Capacities, On Tires, "Stationary Between Tire Tracks"
38	Lifting Capacities, On Tires, "Pick & Carry"
39	Lifting Capacities, On Tires, "Stationary 360°"
40	Patent Information



WARNING

READ AND UNDERSTAND THE OPERATOR'S AND SAFETY MANUAL AND THE FOLLOWING INSTRUCTIONS AND CHART VALUES BEFORE OPERATING THE CRANE. OPERATION WHICH DOES NOT FOLLOW THESE INSTRUCTIONS MAY RESULT IN AN ACCIDENT.

OPERATING INSTRUCTIONS

GENERAL:

1. Rated lifting capacities in pounds as shown on lift charts pertain to this crane as originally manufactured and normally equipped. Modifications to the crane or use of optional equipment other than that specified can result in a reduction of capacity.
2. Construction equipment can be dangerous if improperly operated or maintained. Operation and maintenance of this crane must be in compliance with the information in the Operator's, Parts and Safety Manuals supplied with this crane. If these manuals are missing, order replacements through the distributor.
3. The operator and other personnel associated with this crane shall read and fully understand the latest applicable American National Standards Institute (ANSI) safety standards for cranes.
4. The maximum allowable lifting capacities are based on crane standing level on firm supporting surface.

SET UP:

1. The crane shall be leveled on a firm supporting surface. Depending on the nature of the supporting surface, it may be necessary to have structural supports under the outrigger pontoons or tires to spread the load to a larger bearing surface.
2. When making lifts on outriggers, all tires must be free of supporting surface. All outrigger beams must be extended to the same length; fully retracted, half extended, or fully extended.
3. When making lifts on tires, they must be inflated to the recommended pressure. (See Operation note 19.)
4. For required parts of line, see wire rope strength and winch performance tables.

OPERATION:

1. Rated lifting capacities at rated radius shall not be exceeded. Do not tip the crane to determine allowable loads. For concrete bucket operation, weight of bucket and load shall not exceed 80% of rated lifting capacities. For clamshell bucket operation, weight of bucket and bucket contents is restricted to a maximum weight of 5000 pounds or 80% of rated lifting capacity, whichever is less. For magnet operation, weight of magnet and load is restricted to a maximum weight of 5000 pounds or 80% of rated lifting capacity, whichever is less. For clamshell and magnet operation, maximum boom length is restricted to 46 feet and the boom angle is restricted to a minimum of 38 degrees. Lifts with any fly erected or manual extended are prohibited for both clam and magnet operation.
2. The crane capacities shown on fully extended outriggers do not exceed 85% of the tipping loads. The crane capacities shown on half extended outriggers, fully retracted outriggers or tires do not exceed 75% of the tipping loads as determined by SAE crane stability test code J-765A.
3. The crane capacities in the shaded areas above the bold lines, are based on structural strength or hydraulic limitations. The crane capacities below the bold lines are based on stability ratings.
4. Rated lifting capacities include the weight of hook block, slings, bucket, magnet and auxiliary lifting devices. Their weights must be subtracted from the listed rated capacity to obtain the net load which can be lifted. Also, see deductions for auxiliary head, fixed fly, offset fly, and 25-43 ft. offset telescoping fly.
5. Rated lifting capacities are based on freely suspended loads. No attempt shall be made to move a load horizontally on the ground in any direction.
6. Rated lifting capacities are for crane service only.
7. Do not operate at radii or boom lengths where capacities are not listed. At these positions, the crane can overturn without any load on the hook.

8. The maximum loads which can be telescoped are not definable because of variation in loadings and crane maintenance, but it is permissible to attempt retraction and extension within the limits of the applicable load rating chart.
9. When either boom length or radius or both are between values listed, the smaller load shown at either the next larger radius or boom length shall be used.
10. The user shall operate at reduced ratings to allow for adverse job conditions, such as: soft or uneven ground, out of level conditions, wind, side loads, pendulum action, jerking or sudden stopping of loads, hazardous conditions, experience of personnel, traveling with loads, electrical wires, etc. Side load on boom or fly is extremely dangerous.
11. When making lifts with auxiliary head machinery, the effective length of the boom increases by 2 feet.
12. Power sections of boom must be extended equally.
13. The least stable rated working area on outriggers is over the rear.
14. Rated lifting capacities are based on correct reeving. Deduction must be made for excessive reeving. Any reeving over minimum required (see wire rope strength table) is considered excessive and must be accounted for when making lifts. Use working range diagram to estimate the extra feet of rope then deduct 1 lb. for each extra foot of wire rope before attempting to lift a load.
15. The loaded boom angle combined with the boom length give only an approximation of the operating radius. The boom angle, before loading, should be greater to account for deflection.
16. For fly capacities with main boom length less than 70.25 ft. (manual retracted) or 91 ft. (manual extended) the rated loads are determined by the boom angle only in the fly capacity columns. For angles not shown use the next lower boom angle to determine the allowable capacity.
17. For boom lengths less than 91 ft. with manual extended, the rated loads are determined by boom angle only in the column headed by 91 ft. For angles not shown, use the next lower boom angle to determine allowable capacity.
18. The 28.75 ft. boom length capacities are based on boom fully retracted. If the boom is not fully retracted, do not exceed capacities shown for the 35 ft. boom length.
19. Crane capacities on tires depend on tire capacity, condition of tires, and tire air pressure. On tire picks require lifting from main boom head only on a smooth and level surface. Pick and carry operations (creep) are restricted to a maximum speed of 1 MPH and not exceeding 200 ft. in a 30 minute period. The boom must be centered over the front of the crane with two position travel swing lock engaged and the load must be restrained from swinging. Lifts with manual extended or any fly erected on tires are prohibited. Tire inflation pressure for stationary and creep operations is 80 PSI.

DEFINITIONS:

1. Load Radius: Horizontal distance from a projection of the axis of rotation to the supporting surface before loading to the center of the vertical hoist line or tackle with load applied.
2. Loaded Boom Angle: The angle between the boom base section and horizontal after lifting the load at the rated radius.
3. Working Area: Area measured in a circular arc about the center line of rotation as shown on the working area plate.
4. Freely Suspended Load: Load hanging free with no direct external force applied except by the hoist line.
5. Side Load: Horizontal side force applied to the lifted load either on the ground or in the air.

GENERAL DIMENSIONS

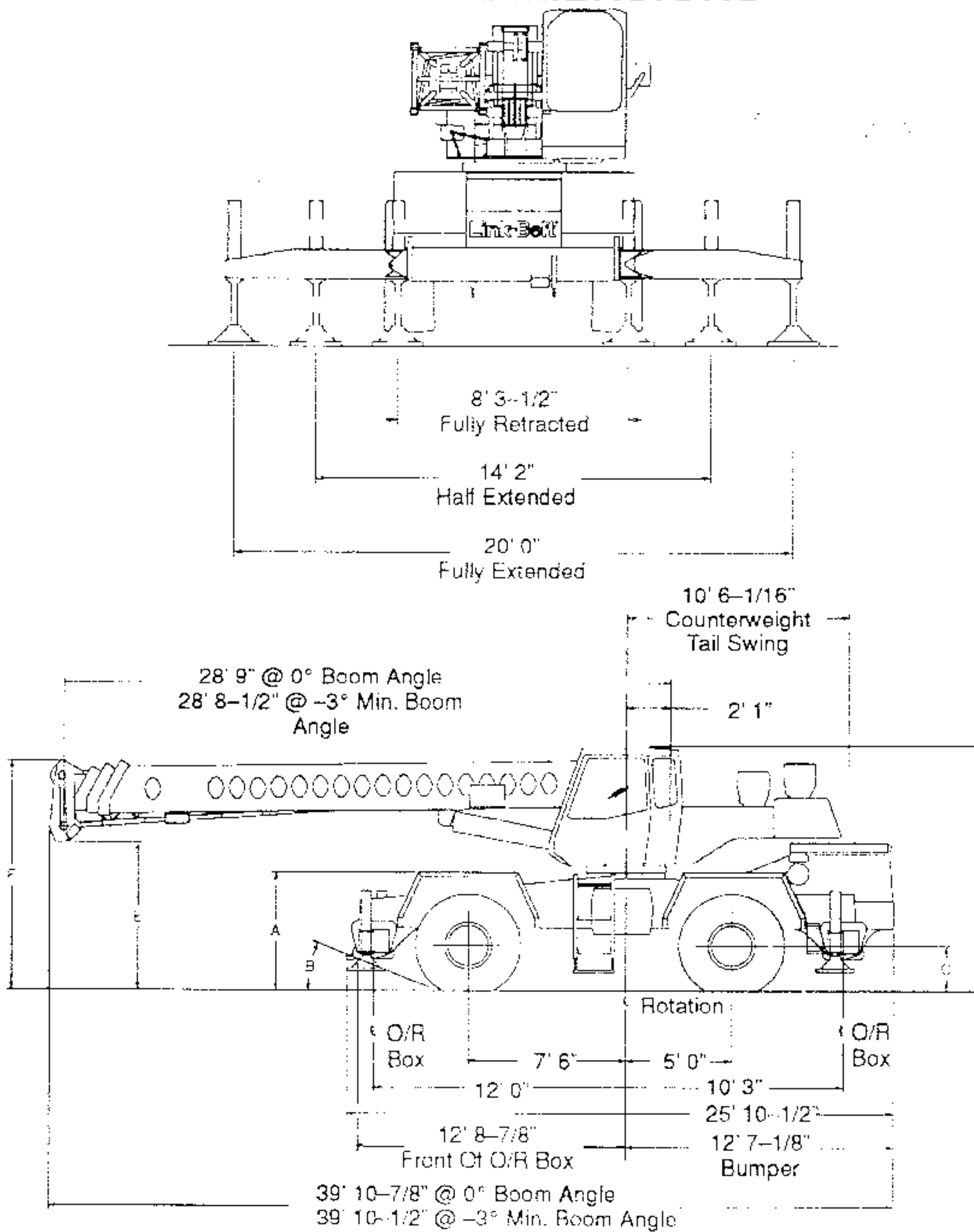

Dimensions Affected By Tires

	Std. Tires 20.5 X 25 (24PR)	Opt. Tires 23.5 X 25 (20 PR)
A	5' 8 -13/16"	5' 10 -13/16"
B	2' 3"	23.5°
C	2' 2-13/16"	2' 4-13/16"
D	11' 4 11/16"	11' 6 11/16"
Boom Angle @ 0°	E	7' 5 1/16"
	F	11' 2-3/16"
Boom Angle @ -3°	F	5' 11"
	G	9' 8-1/8"

Maximum Pontoon Load: 60,000 LBS.

Maximum Pontoon
Ground Bearing Pressure: 150 PSI.

Not To Scale

WINCH PERFORMANCE

Winch Line Pulls				Drum Rope Capacity (Ft.)	
Wire Rope Layer	Two Speed Winch		Single Speed Winch		
	Low Speed Available Lbs.	High Speed Available Lbs.	Available Lbs.		
1	10,360*	5,744	10,547*	62	62 - 62
2	9,325*	5,170	9,492*	69	131
3	8,477	4,700	8,630	76	206
4	7,771	4,309	7,911	82	289
5	7,174	3,977	7,302	89	378

* Reduce to 9,080 Lbs. if using Type RB Rope.

WIRE ROPE STRENGTH

Maximum Lifting Capacities Based On Wire Rope Strength			
Parts of Line	5/8"		Notes
	Type N	Type RB	
1	11,700	9,080*	Capacities shown are in pounds and working loads must not exceed the ratings on the capacity charts in the Crane Rating Manual. Study Operator's Manual for wire rope inspection procedures.
2	23,400	18,160	
3	35,100	27,240	
4	46,800	36,320	
5	58,500	45,400	
6	70,200	54,480	
7	81,900	63,560	
8	93,600	72,640	
LBCE	DESCRIPTION		
TYPE N	6 X 25 (6 X 19) – Filler Wire – Extra Improved Plow Steel – Preformed – I.W.R.C. – Right Lay – Regular Lay		
TYPE RB	18 X 19 Rotation Resistant – Extra Improved Plow Steel – Preformed Right Lay – Regular Lay, Swaged		

* Use of swivel end with 1 part of line is not recommended.

WORKING AREAS

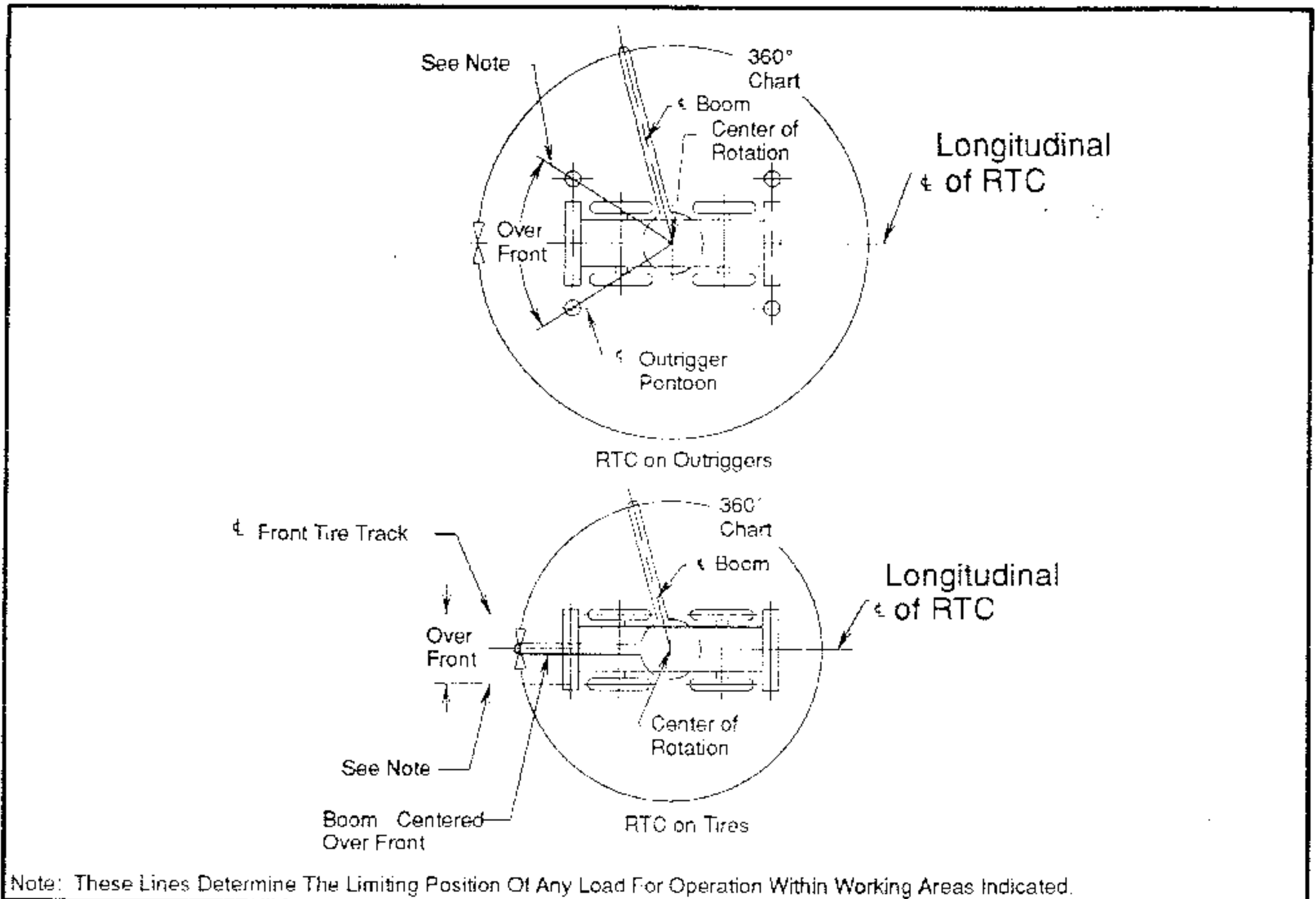

Hydraulic Circuit Pressure Settings

Function	Pressure
Front And Rear Winch	3500 PSI
Outrigger	2500 PSI
Boom Hoist	3000 PSI
Telescope	2500 PSI
Swing	1900 PSI
Steering	2500 PSI
Pilot Control	500 PSI

Capacity Deductions For Auxiliary Load Handling Equipment Lifting From Main Boom With:

Auxiliary Head Attached	125 Lbs.
25 Ft. Fixed Fly Stowed On Base	300 Lbs.
25 Ft. Fixed Fly Erected But Unused	1,000 Lbs.
25 Ft. Offset Fly Stowed On Base	500 Lbs.
25 Ft. Offset Fly Erected But Unused	2,200 Lbs.
25-43 Ft. Offset Telescoping Fly Stowed On Base	750 Lbs.
25-43 Ft. Offset Telescoping Fly Erected But Unused (Retracted)	2,900 Lbs.
25-43 Ft. Offset Telescoping Fly Erected But Unused (Extended)	3,900 Lbs.

**THIS PAGE LEFT BLANK
INTENTIONALLY**

WORKING RANGE DIAGRAM

Working Range Diagram
On Outriggers Fully Extended

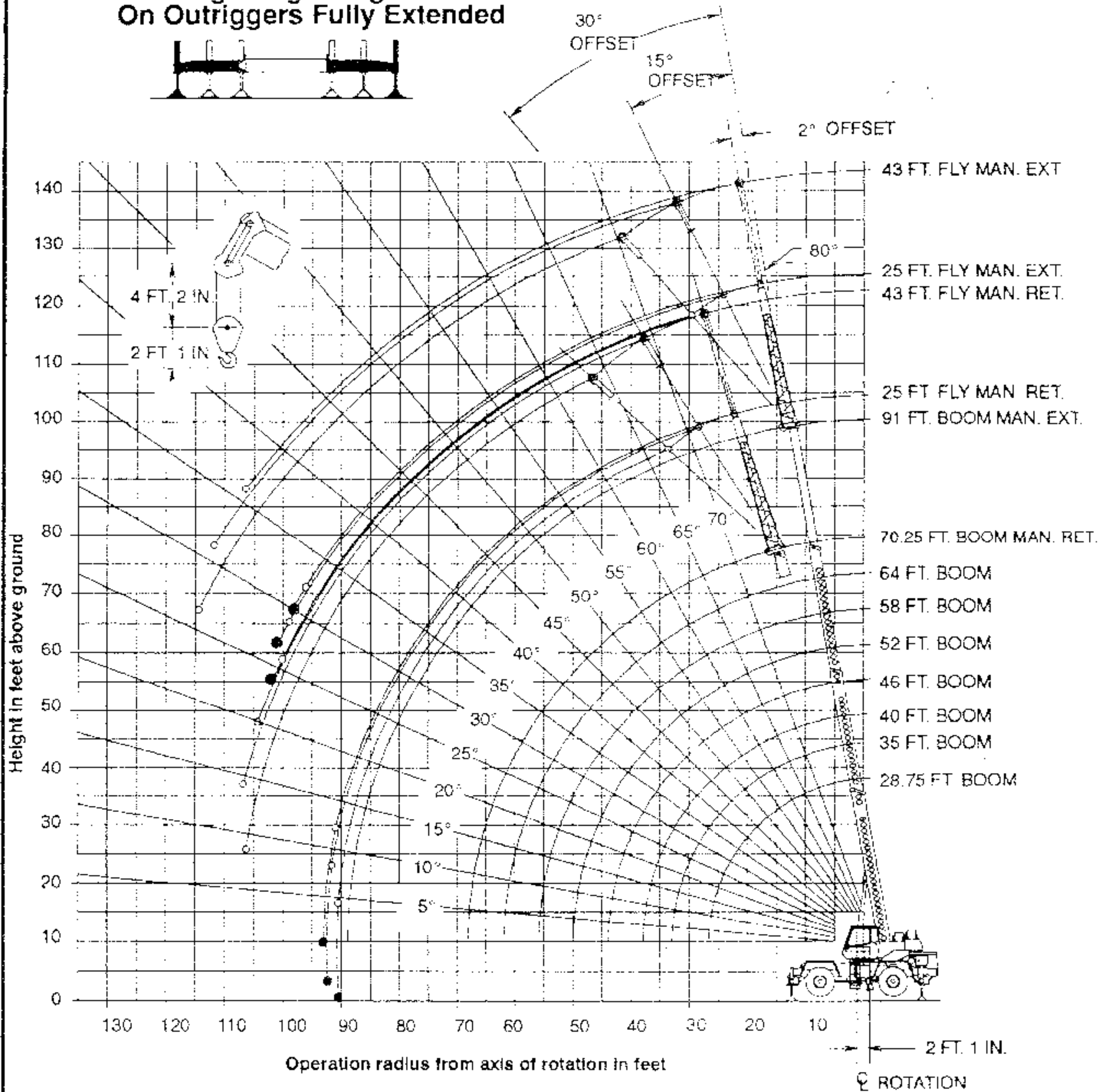

- Denotes 25 Ft. – 43 Ft. Offset Telescoping Fly Minimum Boom Angle For No Load.
- Denotes Offset Fly And Fixed Fly Minimum Boom Angle For No Load.

* Note: Boom and fly geometry shown are for unloaded condition and crane standing level on firm supporting surface. Boom deflection, subsequent radius and boom angle change must be accounted for when applying load to hook.



WARNING

Do Not Lower The Boom Below The Minimum Boom Angle For No Load As Shown In The Above Chart For The Boom Lengths Shown. Loss Of Stability Will Occur Causing A Tipping Condition.

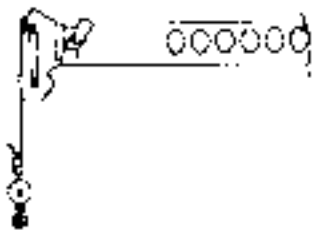

**Maximum Allowable Lifting Capacities
Rated Lifting Capacities In Pounds
On Outriggers Fully Extended
See Set Up Note 2.**

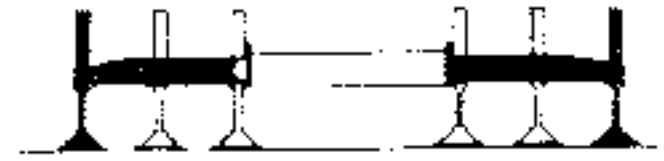

28.75 Ft. To 40 Ft. Main Boom With Manual Retracted

Load Radius In Feet	28.75 Ft.			35 Ft.			40 Ft.			Load Radius In Feet
	Loaded Boom Angle (Deg.)	360°	Over Front	Loaded Boom Angle (Deg.)	360°	Over Front	Loaded Boom Angle (Deg.)	360°	Over Front	
10	66.0	60,000	60,000	70.5	48,600	48,600	73.5	47,800	47,800	10
12	61.5	54,000	54,000	67.0	48,600	48,600	70.5	47,800	47,800	12
15	54.5	42,900	42,900	61.5	42,800	42,800	66.0	42,800	42,800	15
20	40.5	30,700	30,700	52.0	30,700	30,700	57.5	30,700	30,700	20
25	20.5	22,700	22,700	40.0	22,700	22,700	48.5	22,700	22,700	25
30				24.5	18,500	18,500	37.5	18,500	18,500	30
35	(See Note 18.)						23.0	14,600	15,100	35
Zero Angle Capacity		12,000	13,200		8,100	9,900		6,200	8,100	Zero Angle Capacity

46 Ft. To 58 Ft. Main Boom With Manual Retracted

Load Radius In Feet	46 Ft.			52 Ft.			58 Ft.			Load Radius In Feet
	Loaded Boom Angle (Deg.)	360°	Over Front	Loaded Boom Angle (Deg.)	360°	Over Front	Loaded Boom Angle (Deg.)	360°	Over Front	
10	76.0	47,200	47,200	78.0	46,800	46,800				10
12	73.5	47,200	47,200	76.0	43,800	43,800	77.5	40,200	40,200	12
15	69.5	41,500	41,500	72.5	37,600	37,600	74.5	34,900	34,900	15
20	62.5	30,700	30,700	66.5	30,300	30,300	69.5	28,000	28,000	20
25	55.0	22,700	22,700	60.0	22,700	22,700	64.0	22,700	22,700	25
30	47.0	18,500	18,500	53.5	18,500	18,500	58.0	18,500	18,500	30
35	37.5	14,600	15,100	46.0	14,600	15,100	52.0	14,600	15,100	35
40	25.0	11,400	12,500	37.5	11,400	12,500	45.0	11,400	12,500	40
45				26.5	9,100	10,500	37.5	9,100	10,500	45
50							27.5	7,400	8,900	50
Zero Angle Capacity		4,700	6,400		3,600	5,200		2,800	4,200	Zero Angle Capacity

Note: Refer To Page 7 For "Lifting Capacity Deductions" For Capacity Reductions Caused By Stowed Or Erected Auxillary Load Handling Equipment.

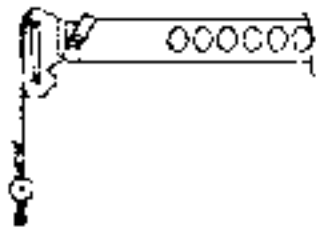

**Maximum Allowable Lifting Capacities
Rated Lifting Capacities In Pounds
On Outriggers Fully Extended
See Set Up Note 2.**

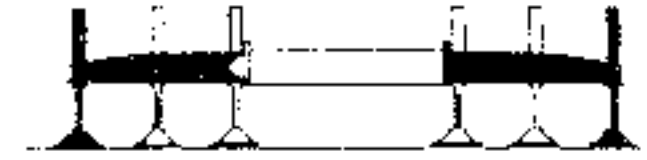

64 Ft. To 70.25 Ft. Main Boom Manual Retracted

Load Radius In Feet	64 Ft.			70.25 Ft.			Load Radius In Feet
	Loaded Boom Angle (Deg.)	360°	Over Front	Loaded Boom Angle (Deg.)	360°	Over Front	
15	76.5	32,100	32,100	78.0	28,500	28,500	15
20	72.0	26,400	26,400	74.0	24,100	24,100	20
25	67.0	21,900	21,900	70.0	20,700	20,700	25
30	62.0	18,500	18,500	65.5	17,600	17,600	30
35	56.5	14,600	15,100	60.5	14,600	15,100	35
40	51.0	11,400	12,500	55.5	11,400	12,500	40
45	44.5	9,100	10,500	50.0	9,100	10,500	45
50	37.5	7,400	8,900	44.5	7,400	8,900	50
55	28.5	6,000	7,600	37.5	6,000	7,600	55
60	15.5	4,900	6,500	30.0	4,900	6,500	60
65				19.0	4,000	5,500	65
Zero Angle Capacity		2,200	3,400		1,700	2,800	Zero Angle Capacity

Note: Refer To Page 7 For "Lifting Capacity Deductions" For Capacity Reductions Caused By Stowed Or Erected Auxilliary Load Handling Equipment.

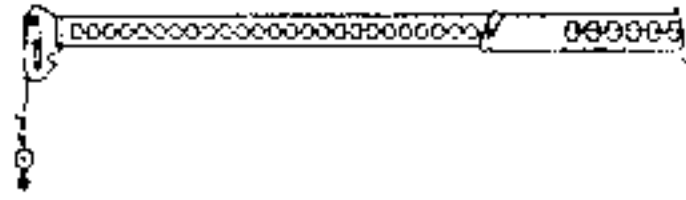

**Maximum Allowable Lifting Capacities
Rated Lifting Capacities in Pounds
On Outriggers Fully Extended
See Set Up Note 2.**

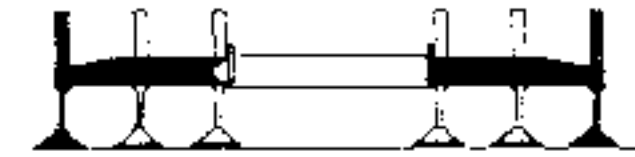

91 Ft. Main Boom Manual Extended

Load Radius In Feet	91 Ft.			Load Radius In Feet
	Loaded Boom Angle (Deg.)	360°	Over Front	
20	79.0	18,600	18,600	20
25	75.5	16,300	16,300	25
30	72.5	14,500	14,500	30
35	69.0	12,900	12,900	35
40	66.0	11,400	11,400	40
45	62.5	10,100	10,200	45
50	58.5	8,400	8,900	50
55	54.5	7,000	8,200	55
60	50.5	5,900	7,300	60
65	46.0	4,900	6,400	65
70	41.0	4,200	5,600	70
75	35.5	3,500	4,900	75
80	28.5	3,000	4,300	80
85	20.0	2,500	3,800	85

Minimum Boom Angle For No Load: 0°

Note: Refer To Page 7 For "Lifting Capacity Deductions" For Capacity Reductions Caused By Stowed Or Erected Auxilliary Load Handling Equipment.

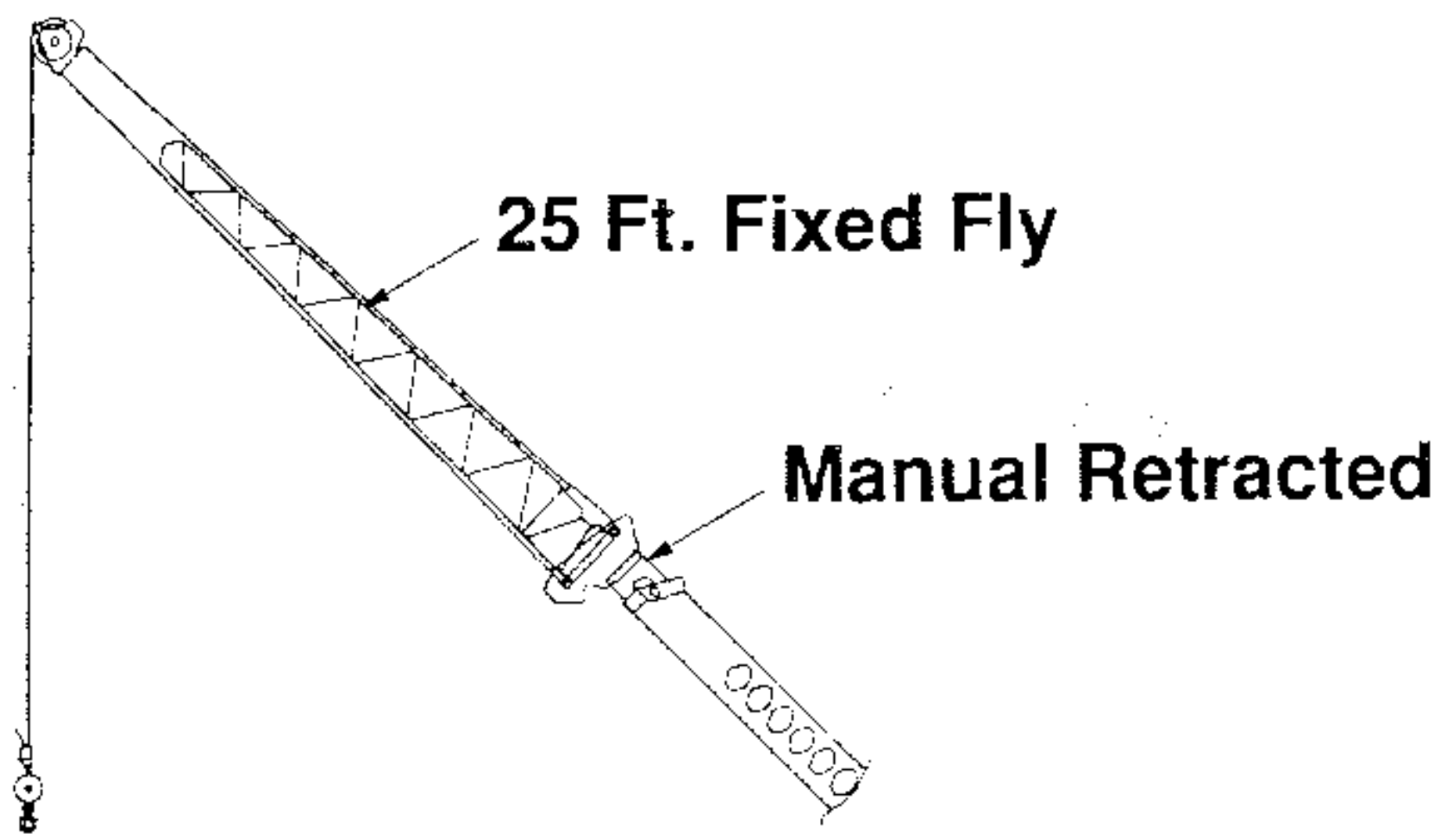

Maximum Allowable Lifting Capacities Rated Lifting Capacities In Pounds On Outriggers Fully Extended See Set Up Note 2.				
70.25 Ft. Main Boom Manual Retracted + 25 Ft. Fixed Fly				
Load Radius In Feet	95.25 Ft.			Load Radius In Feet
	Loaded Boom Angle (Deg.)	360°	Over Front	
20	78.5	16,200	16,200	20
25	75.5	13,900	13,900	25
30	72.5	12,200	12,200	30
35	69.5	10,900	10,900	35
40	66.0	9,800	9,800	40
45	63.0	8,800	8,800	45
50	59.5	8,100	8,100	50
55	55.5	7,100	7,500	55
60	52.0	6,000	7,000	60
65	48.0	5,100	6,400	65
70	43.5	4,300	5,700	70
75	38.5	3,700	5,000	75
80	32.5	3,100	4,400	80
85	26.0	2,700	3,900	85
90	17.0	2,200	3,400	90

Minimum Boom Angle For No Load: 0°

Note: Refer To Page 7 For "Lifting Capacity Deductions" For Capacity Reductions Caused By Stowed Or Erected Auxiliary Load Handling Equipment.

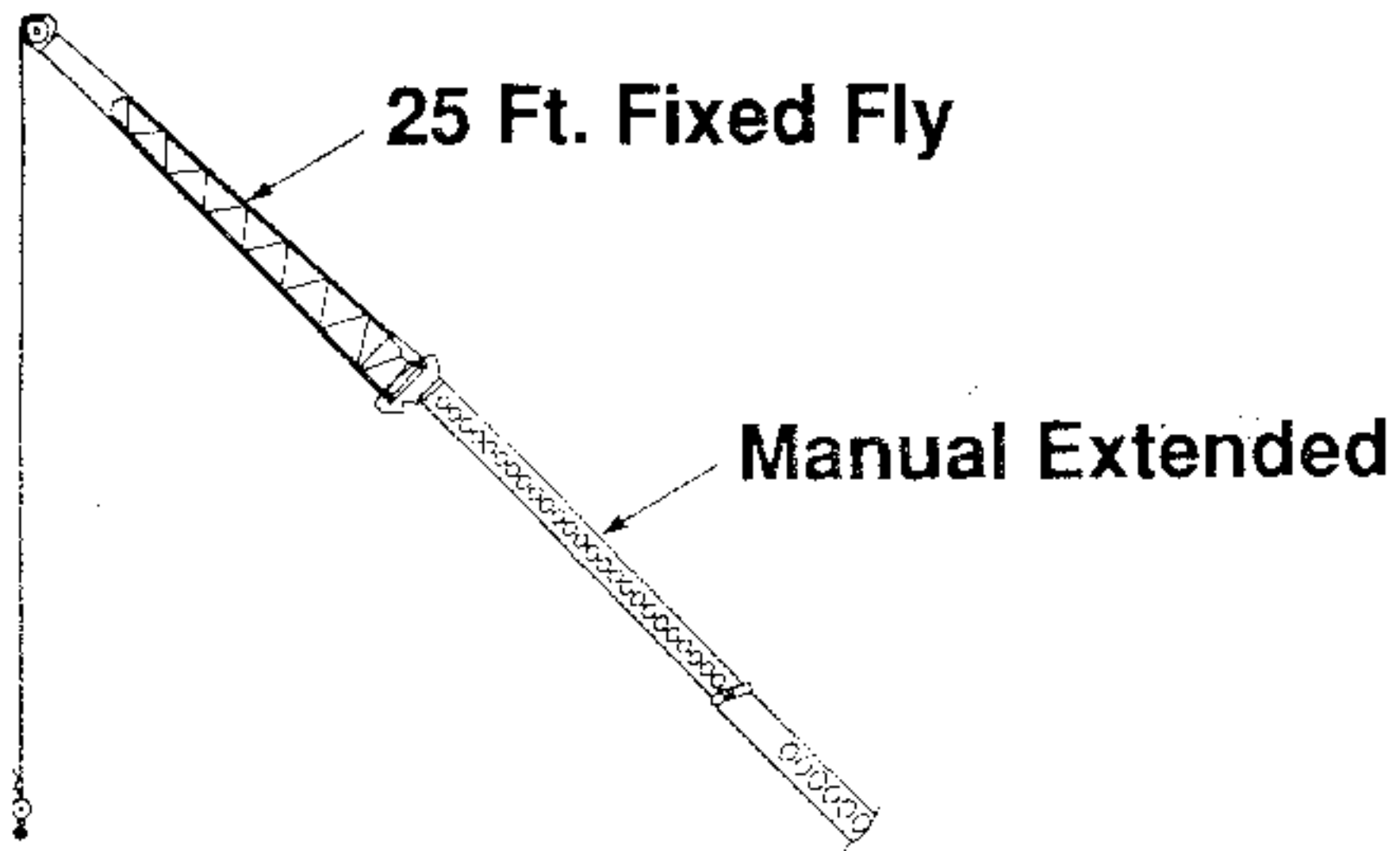

Maximum Allowable Lifting Capacities Rated Lifting Capacities In Pounds On Outriggers Fully Extended See Set Up Note 2.				
91 Ft. Main Boom Manual Extended + 25 FT. Fixed Fly				
Load Radius In Feet	116 Ft.			Load Radius In Feet
	Loaded Boom Angle (Deg.)	360°	Over Front	
30	77.5	10,300	10,300	30
35	75.0	9,000	9,000	35
40	72.5	8,100	8,100	40
45	69.5	7,200	7,200	45
50	67.0	6,500	6,500	50
55	64.0	5,900	5,900	55
60	61.5	5,400	5,400	60
65	58.5	5,000	5,000	65
70	55.5	4,600	4,600	70
75	52.0	4,100	4,200	75
80	49.0	3,500	3,900	80
85	45.0	3,000	3,500	85
90	41.5	2,600	3,300	90
95	38.0	2,300	3,000	95
100	32.0	1,900	2,800	100
105	26.5	1,600	2,600	105



WARNING

Do Not Lower 25 Ft. Fixed Fly in Working Position Below 13 Degrees Unless Main Boom Length is 88 Ft. Or Less, Since Loss Of Stability Will Occur Causing a Tipping Condition.

Note: Refer To Page 7 For "Lifting Capacity Deductions" For Capacity Reductions Caused By Stowed Or Erected Auxillary Load Handling Equipment.

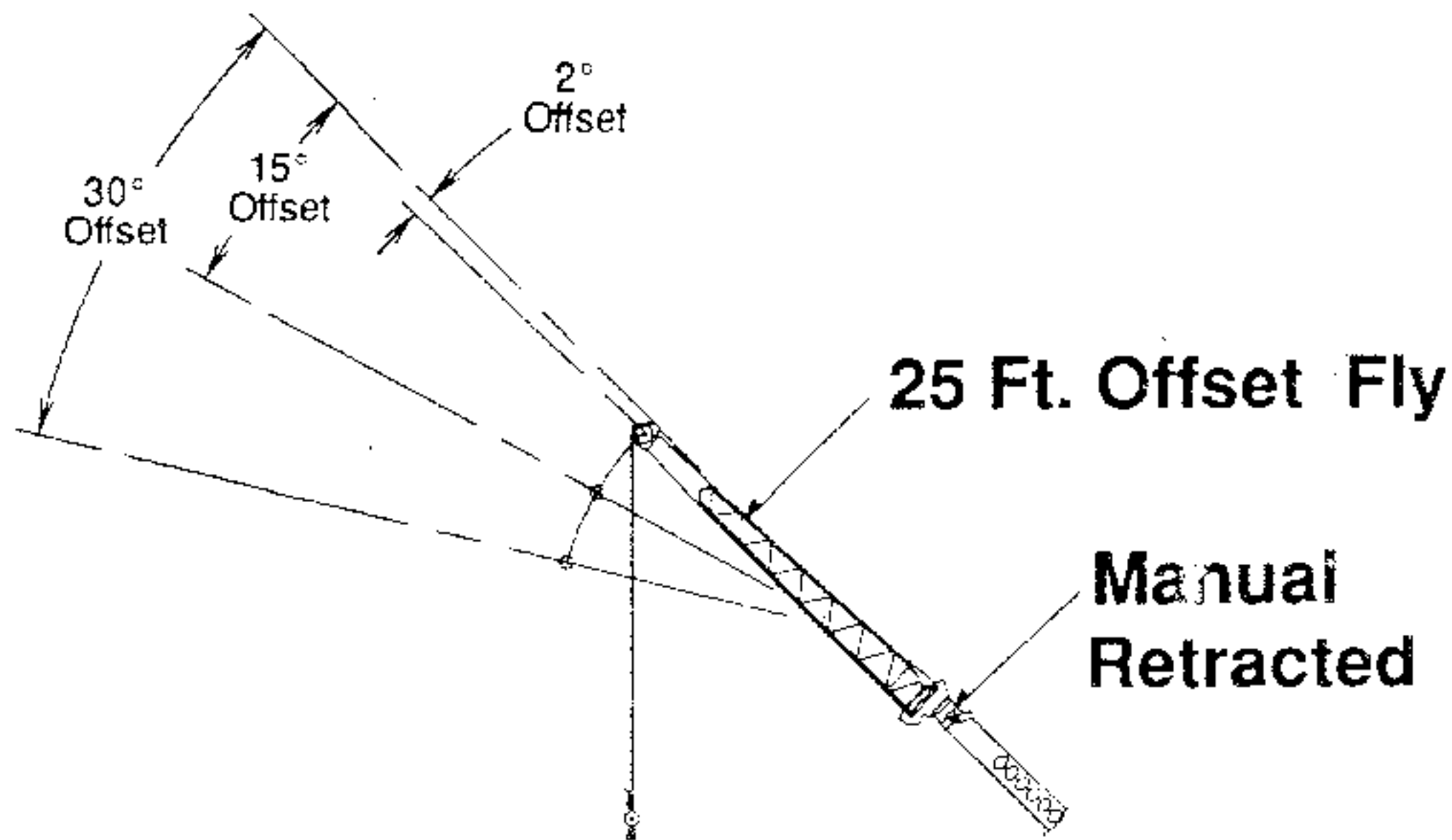

Maximum Allowable Lifting Capacities Rated Lifting Capacities In Pounds On Outriggers Fully Extended See Set Up Note 2.							
70.25 Ft. Main Boom Manual Retracted + 25 Ft. Offset Fly							
Load Radius In Feet	2° Offset		15° Offset		30° Offset		Load Radius In Feet
	Loaded Boom Angle (Deg.)	360°	Loaded Boom Angle (Deg.)	360°	Loaded Boom Angle (Deg.)	360°	
20	78.5	13,000					20
25	75.5	11,900	79.0	9,100			25
30	72.5	10,900	76.0	8,500	79.0	6,400	30
35	69.5	9,800	73.0	7,800	76.0	6,000	35
40	66.5	9,200	69.5	7,200	72.5	5,700	40
45	63.0	8,500	66.0	6,600	69.5	5,400	45
50	59.5	7,700	62.5	6,100	65.5	5,200	50
55	56.0	6,800	59.0	5,800	62.0	4,900	55
60	52.0	5,700	55.0	5,400	58.0	4,700	60
65	48.0	4,800	51.0	5,100	54.0	4,600	65
70	43.5	4,000	46.5	4,300	49.0	4,300	70
75	38.5	3,400	41.5	3,600	44.0	3,700	75
80	33.0	2,800	36.0	3,000	38.0	3,100	80
85	26.5	2,400	29.0	2,400	30.0	2,500	85
90	17.5	1,900	19.5	2,000	17.0	1,900	90

Minimum Boom Angle For No Load: 0°

Note: Refer To Page 7 For "Lifting Capacity Deductions" For Capacity Reductions Caused By Stowed Or Erected Auxillary Load Handling Equipment.

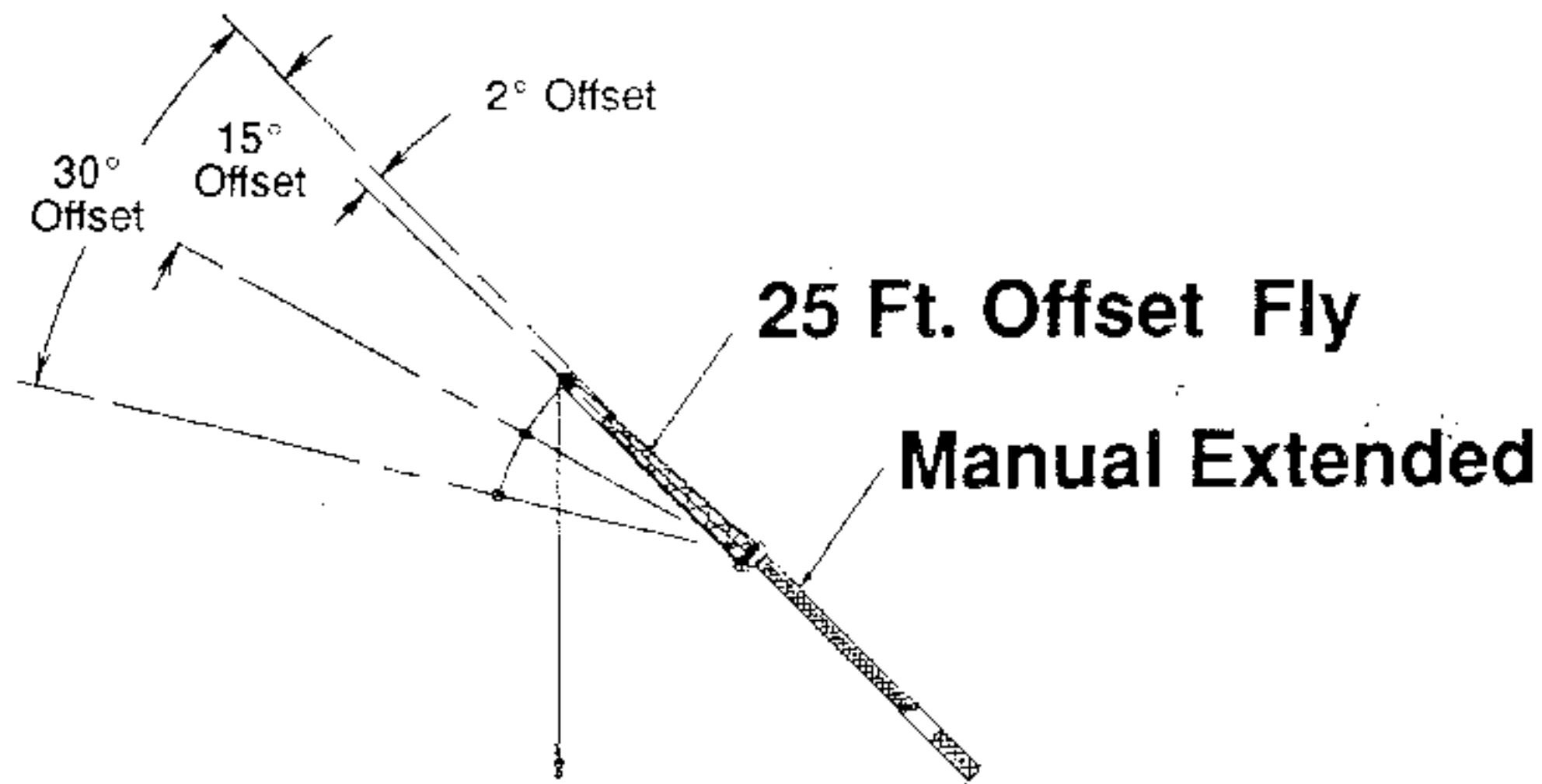

Maximum Allowable Lifting Capacities Rated Lifting Capacities In Pounds On Outriggers Fully Extended See Set Up Note 2.							
91 Ft. Main Boom Manual Extended + 25 Ft. Offset Fly							
Load Radius In Feet	2° Offset		15° Offset		30° Offset		Load Radius In Feet
	Loaded Boom Angle (Deg.)	360°	Loaded Boom Angle (Deg.)	360°	Loaded Boom Angle (Deg.)	360°	
25	79.5	10,300					25
30	77.0	9,100	80.0	8,400			30
35	75.0	8,100	77.5	7,400	80.0	6,400	35
40	72.5	7,300	75.0	6,600	77.5	5,900	40
45	70.0	6,600	72.5	5,900	75.0	5,300	45
50	67.0	5,900	70.0	5,300	72.5	4,900	50
55	64.5	5,400	67.0	4,800	69.5	4,500	55
60	61.5	4,900	64.0	4,400	66.5	4,100	60
65	58.5	4,500	61.0	4,100	63.5	3,800	65
70	55.5	4,100	58.0	3,700	60.5	3,500	70
75	52.0	3,700	55.0	3,400	57.0	3,300	75
80	49.0	3,200	51.5	3,200	53.5	3,100	80
85	45.0	2,700	48.0	2,900	49.5	2,900	85
90	41.0	2,300	44.0	2,400	45.5	2,500	90
95	37.0	1,900	39.5	2,000	41.0	2,100	95
100	32.0	1,600	34.5	1,700	35.5	1,700	100
105	26.5	1,300	29.5	1,400	29.5	1,400	105

WARNING
Do Not Lower 25 Ft. Offset Fly In Working Position Below 25 Degrees Unless Main Boom Length Is 81 Ft. Or Less, Since Loss Of Stability Will Occur Causing A Tipping Condition.

Note: Refer To Page 7 For "Lifting Capacity Deductions" For Capacity Reductions Caused By Stowed Or Erected Auxilliary Load Handling Equipment.

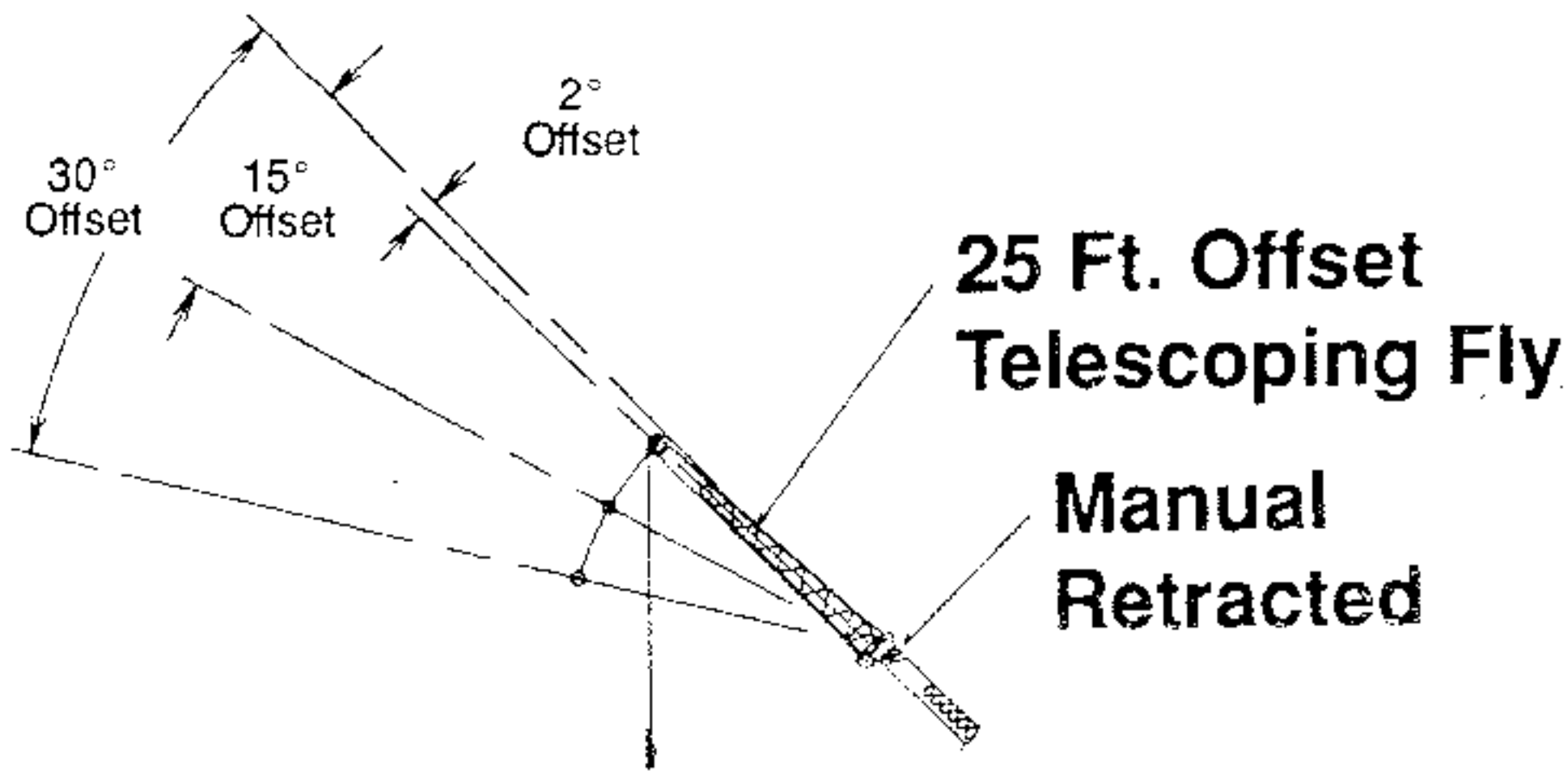

**Maximum Allowable Lifting Capacities
Rated Lifting Capacities In Pounds
On Outriggers Fully Extended
See Set Up Note 2.**

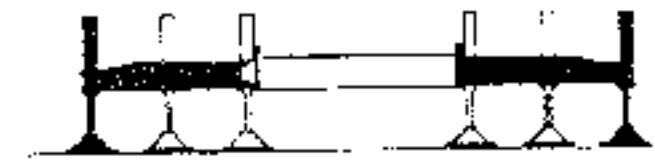

70.25 Ft. Main Boom Manual Retracted + 25 Ft. Offset Telescoping Fly

Load Radius In Feet	25 Ft.						Load Radius In Feet
	2° Offset		15° Offset		30° Offset		
	Loaded Boom Angle (Deg.)	360°	Loaded Boom Angle (Deg.)	360°	Loaded Boom Angle (Deg.)	360°	
20	78.5	12,700					20
25	75.5	11,500	79.0	8,800			25
30	72.5	10,600	76.0	8,200	79.0	6,100	30
35	69.5	9,600	73.0	7,500	76.0	5,700	35
40	66.0	8,700	69.5	6,900	72.5	5,400	40
45	63.0	8,000	66.0	6,400	69.0	5,100	45
50	59.5	7,400	62.5	5,900	65.5	4,800	50
55	56.0	6,500	59.0	5,300	62.0	4,500	55
60	52.0	5,400	55.0	4,900	58.0	4,200	60
65	48.0	4,500	51.0	4,500	53.5	3,900	65
70	43.5	3,700	46.5	3,900	49.0	3,600	70
75	38.5	3,000	41.5	3,200	44.0	3,400	75
80	33.0	2,500	36.0	2,600	37.5		80
85	26.5	2,000	29.0	2,100	30.0	2,100	85
90	17.5	1,600	19.5	1,600	17.0	1,600	90



WARNING

Do Not Lower 25 Ft. Offset Telescoping Fly In Working Position Below 12 Degrees Unless Main Boom Length Is 68 Ft. Or Less, Since Loss Of Stability Will Occur Causing A Tipping Condition.

Note: Refer To Page 7 For "Lifting Capacity Deductions" For Capacity Reductions Caused By Stowed Or Erected Auxillary Load Handling Equipment.

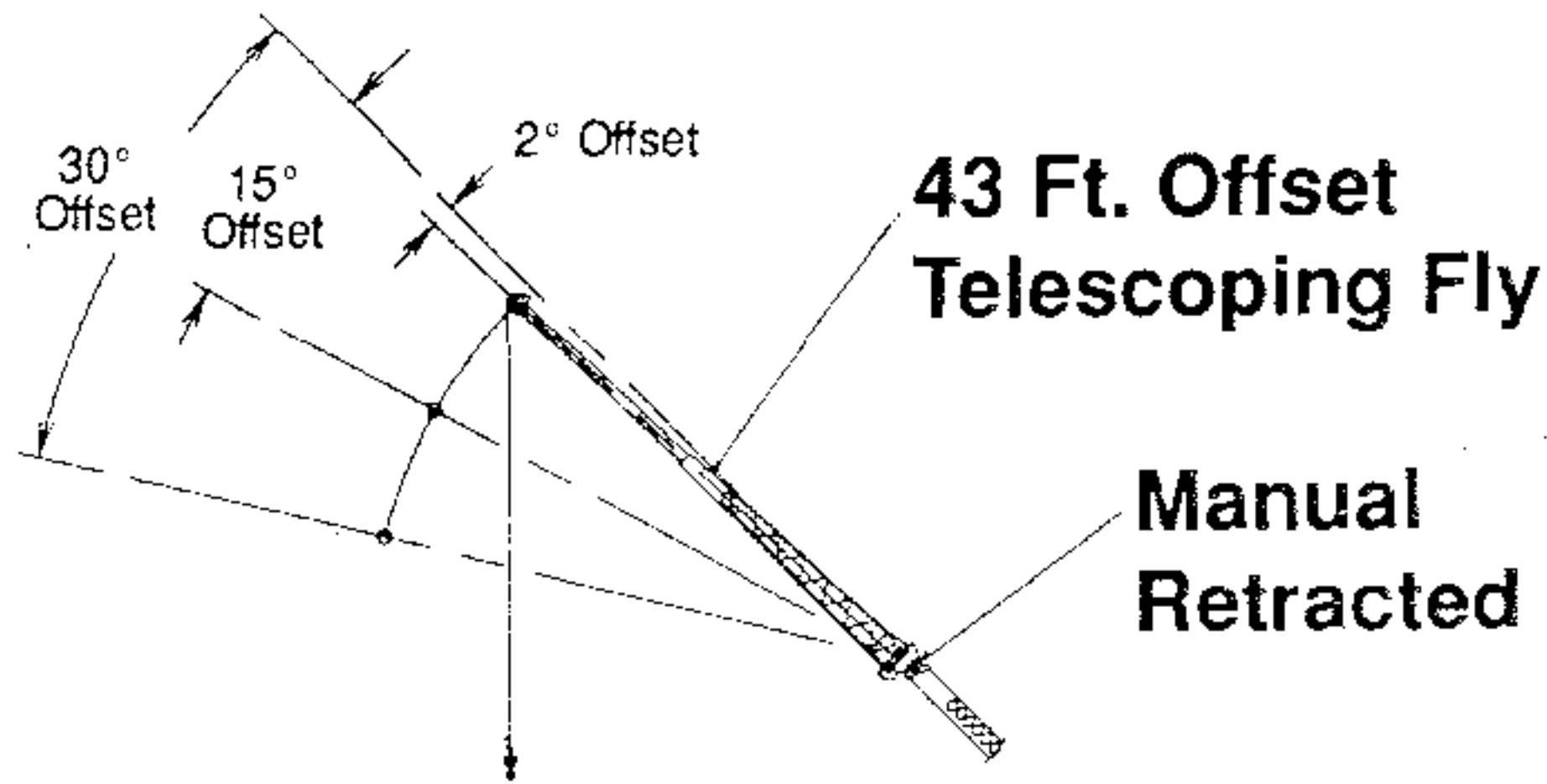

Maximum Allowable Lifting Capacities
Rated Lifting Capacities In Pounds
On Outriggers Fully Extended
See Set Up Note 2.



70.25 Ft. Main Boom Manual Retracted + 43 Ft. Offset Telescoping Fly

Load Radius In Feet	43 Ft.						Load Radius In Feet
	2° Offset		15° Offset		30° Offset		
	Loaded Boom Angle (Deg.)	360°	Loaded Boom Angle (Deg.)	360°	Loaded Boom Angle (Deg.)	360°	
25	77.5	4,900					25
30	75.5	4,700					30
35	73.0	4,500	78.0	4,000			35
40	70.0	4,300	75.5	3,900			40
45	67.5	4,100	72.5	3,700	77.5	3,000	45
50	65.0	3,900	70.0	3,500	74.5	2,900	50
55	62.0	3,800	67.0	3,300	71.5	2,700	55
60	59.5	3,700	64.0	3,100	68.5	2,600	60
65	56.5	3,500	61.0	2,900	65.5	2,500	65
70	53.5	3,200	58.0	2,800	62.5	2,400	70
75	50.0	3,000	54.5	2,600	59.0	2,300	75
80	46.5	2,800	51.0	2,500	55.0	2,200	80
85	43.0	2,700	47.5	2,400	51.0	2,100	85
90	38.5	2,300	43.0	2,300	46.5	2,000	90
95	34.0	2,000	38.5	2,200	41.5	2,000	95
100	28.5	1,600	33.0	1,800	35.5	1,900	100
105			25.5	1,400	26.0	1,400	105

⚠ WARNING

Do Not Lower 43 Ft. Offset Telescoping Fly in Working Position Below 20 Degrees Unless Main Boom Length Is 65 Ft. Or Less, Since Loss Of Stability Will Occur Causing A Tipping Condition.

Note: Refer To Page 7 For "Lifting Capacity Deductions" For Capacity Reductions Caused By Stowed Or Erected Auxiliary Load Handling Equipment.

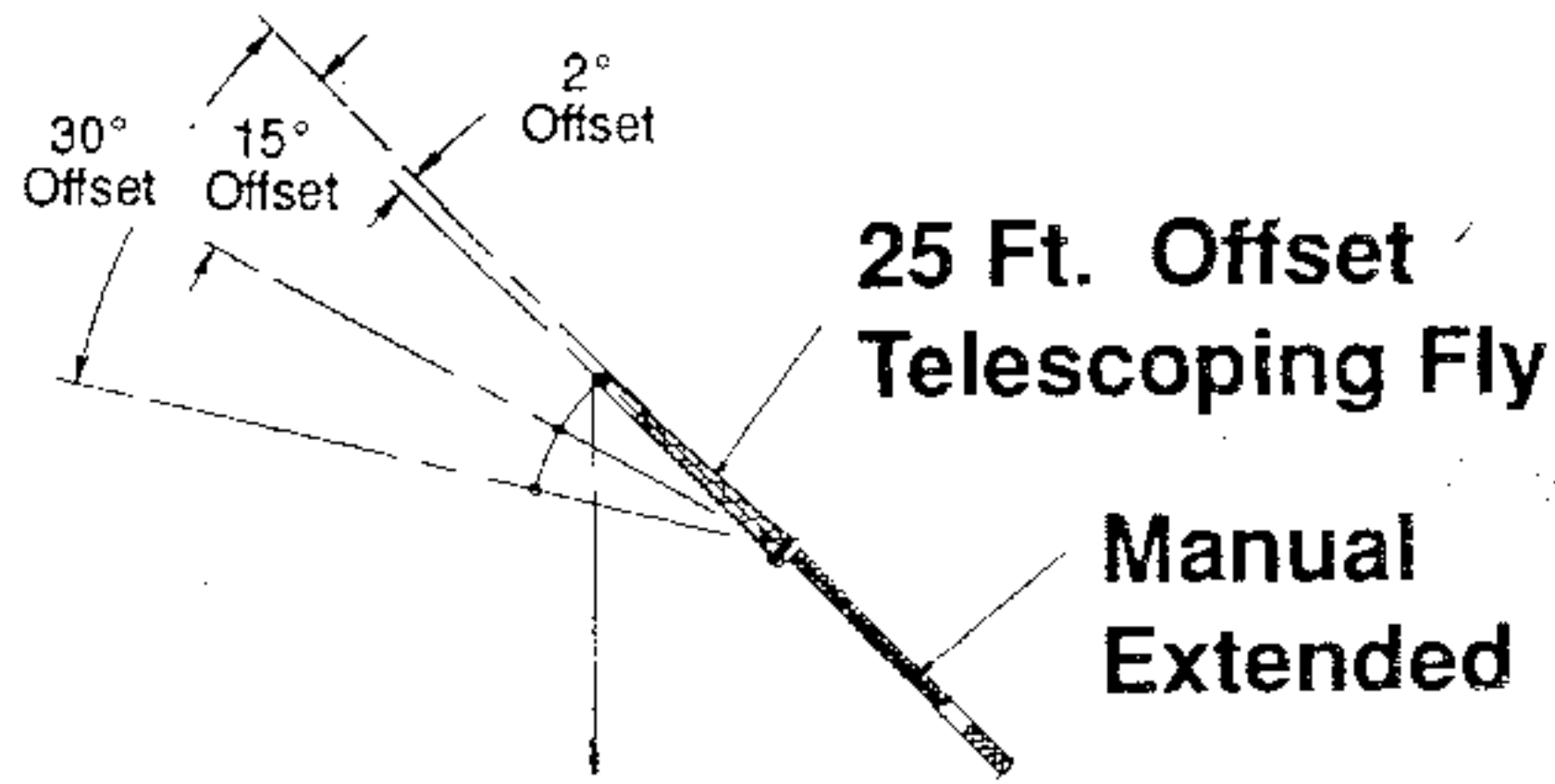

Maximum Allowable Lifting Capacities Rated Lifting Capacities In Pounds On Outriggers Fully Extended See Set Up Note 2.							
91 Ft. Main Boom Manual Extended + 25 Ft. Offset Telescoping Fly							
Load Radius In Feet	25 Ft.						Load Radius In Feet
	2° Offset		15° Offset		30° Offset		
	Loaded Boom Angle (Deg.)	360°	Loaded Boom Angle (Deg.)	360°	Loaded Boom Angle (Deg.)	360°	
25	79.5	9,900					25
30	77.0	8,700	80.0	8,000			30
35	75.0	7,700	77.5	7,000	80.0	6,000	35
40	72.5	6,900	75.0	6,200	77.5	5,500	40
45	70.0	6,100	72.5	5,500	75.0	5,000	45
50	67.0	5,500	70.0	4,900	72.5	4,500	50
55	64.5	4,900	67.0	4,500	69.5	4,100	55
60	61.5	4,400	64.0	4,000	66.5	3,700	60
65	58.5	4,000	61.0	3,700	63.5	3,400	65
70	55.5	3,600	58.0	3,400	60.5	3,200	70
75	52.0	3,200	55.0	3,100	57.0	2,900	75
80	49.0	2,800	51.5	2,800	53.5	2,700	80
85	45.0	2,400	48.0	2,500	49.5	2,500	85
90	41.0	1,900	44.0	2,100	45.5	2,200	90
95	37.0	1,600	39.5	1,700	41.0	1,900	95
100	32.0	1,200	34.5	1,300	35.5	1,400	100

! WARNING

Do Not Lower 25 Ft. Offset Telescoping Fly In Working Position Below 32 Degrees Unless Main Boom Length Is 76 Ft. Or Less, Since Loss Of Stability Will Occur Causing A Tipping Condition.

Note: Refer To Page 7 For "Lifting Capacity Deductions" For Capacity Reductions Caused By Stowed Or Erected Auxiliary Load Handling Equipment.

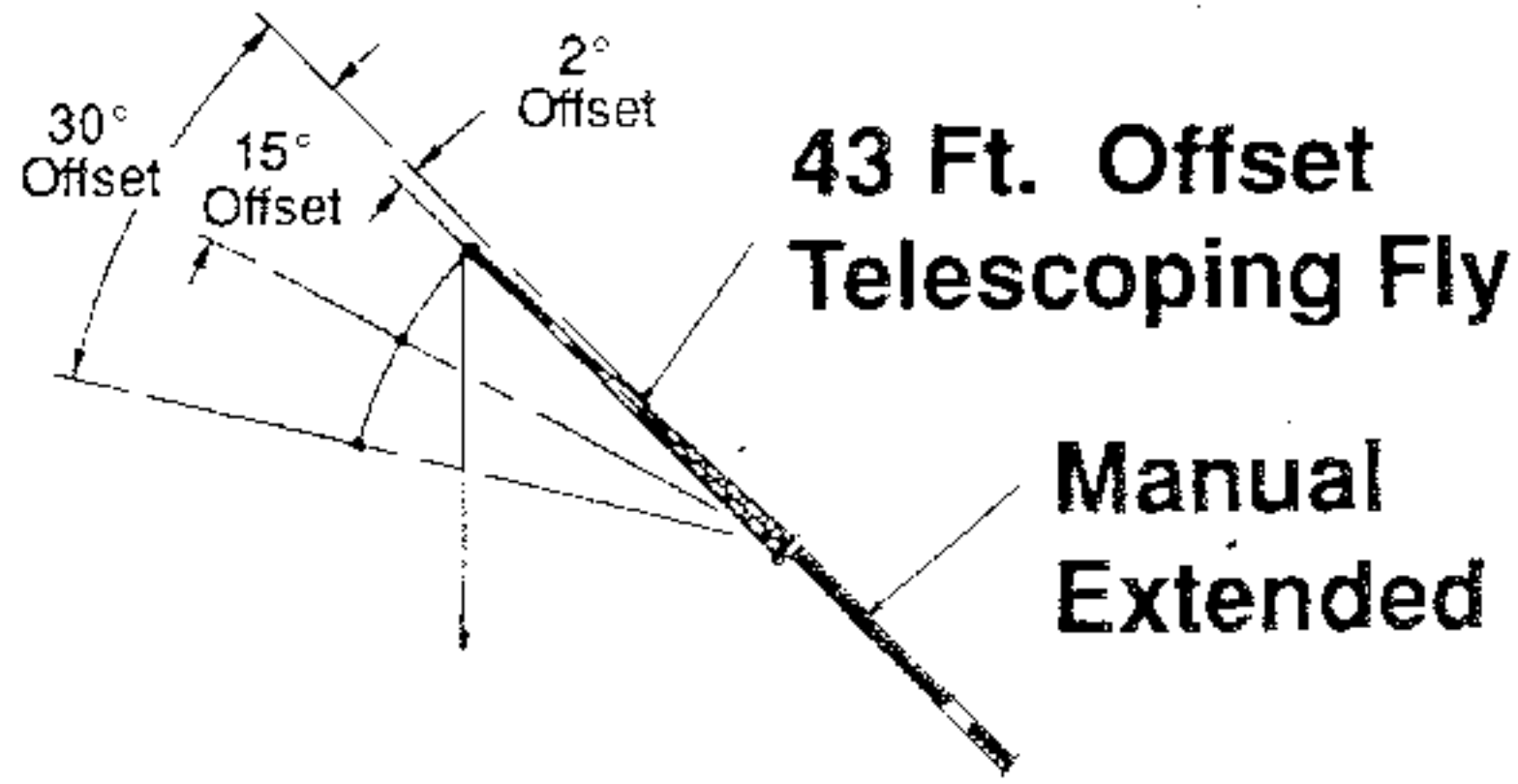

**Maximum Allowable Lifting Capacities
Rated Lifting Capacities in Pounds
On Outriggers Fully Extended
See Set Up Note 2.**

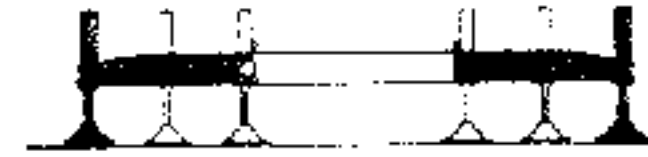

91 Ft. Main Boom Manual Extended + 43 Ft. Offset Telescoping Fly

Load Radius In Feet	43 Ft.						Load Radius In Feet
	2° Offset		15° Offset		30° Offset		
	Loaded Boom Angle (Deg.)	360°	Loaded Boom Angle (Deg.)	360°	Loaded Boom Angle (Deg.)	360°	
35	78.0	4,900					35
40	75.5	4,700	79.0	4,000			40
45	73.5	4,500	77.5	3,900			45
50	71.5	4,300	75.5	3,700	79.0	3,100	50
55	69.0	3,900	73.0	3,400	77.0	3,000	55
60	66.5	3,500	70.5	3,100	74.5	2,800	60
65	64.5	3,100	68.0	2,800	72.0	2,600	65
70	62.0	2,800	65.5	2,600	69.5	2,400	70
75	59.0	2,500	63.0	2,300	66.5	2,200	75
80	56.5	2,300	60.5	2,100	64.0	2,000	80
85	54.0	2,000	58.0	2,000	61.0	1,800	85
90	51.0	1,700	54.5	1,700	58.0	1,700	90
95	48.0	1,500	51.5	1,600	54.5	1,600	95
100	45.0	1,300	48.5	1,400	51.5	1,400	100
105	41.0	1,100	45.0	1,200	48.0	1,200	105
110	37.5	900	41.0	1,000	43.5	1,100	110
115			37.0	900	39.0	900	115



WARNING

Do Not Lower 43 Ft. Offset Telescoping Fly In Working Position Below 36 Degrees Unless Main Boom Length Is 72 Ft. Or Less, Since Loss Of Stability Will Occur Causing A Tipping Condition.

Note: Refer To Page 7 For "Lifting Capacity Deductions" For Capacity Reductions Caused By Stowed Or Erected Auxiliary Load Handling Equipment.

WORKING RANGE DIAGRAM

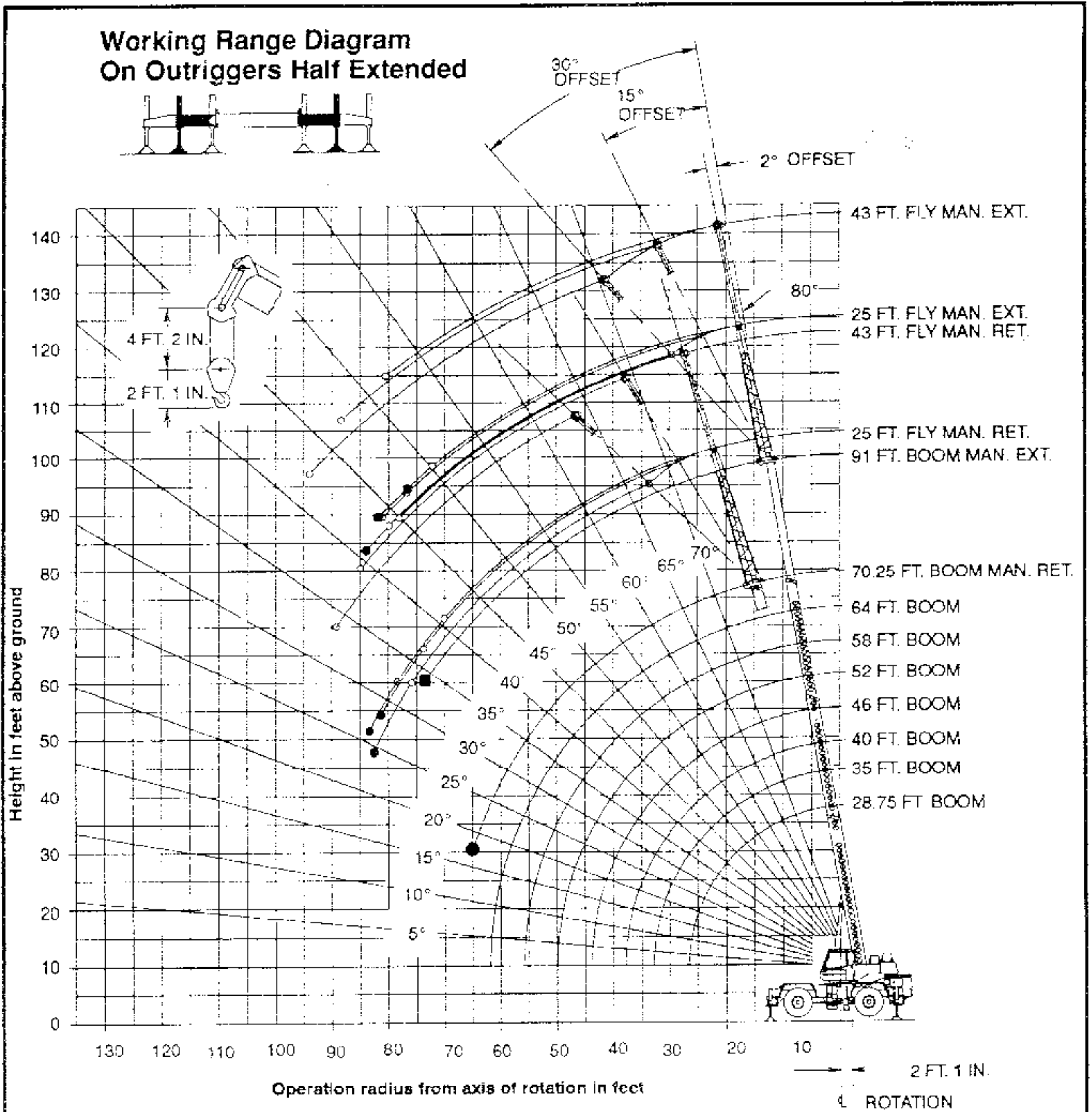

- Denotes Main Boom With Manual Retracted Minimum Boom Angle For No Load.
- Denotes 91 Ft. Main Boom With Manual Extended Minimum Boom Angle For No Load.
- Denotes 25 Ft. – 43 Ft. Offset Telescoping Fly Minimum Boom Angle For No Load.
- Denotes Offset Fly And Fixed Fly Minimum Boom Angle For No Load.

* Note: Boom and fly geometry shown are for unloaded condition and crane standing level on firm supporting surface. Boom deflection, subsequent radius and boom angle change must be accounted for when applying load to hook.

WARNING

Do Not Lower The Boom Below The Minimum Boom Angle For No Load As Shown In The Above Chart For The Boom Lengths Shown. Loss Of Stability Will Occur Causing A Tipping Condition.

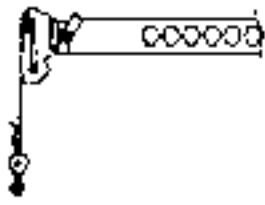

**Maximum Allowable Lifting Capacities
Rated Lifting Capacities In Pounds
On Outriggers Half Extended
See Set Up Note 2.**

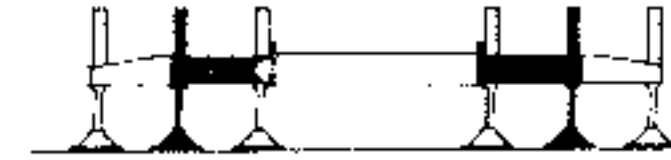

28.75 Ft. To 40 Ft. Main Boom With Manual Retracted

Load Radius In Feet	28.75 Ft.		35 Ft.		40 Ft.		Load Radius In Feet
	Loaded Boom Angle (Deg.)	360°	Loaded Boom Angle (Deg.)	360°	Loaded Boom Angle (Deg.)	360°	
10	66.0	60,000	70.5	48,600	73.5	47,800	10
12	61.5	54,000	67.0	48,600	70.5	47,800	12
15	54.5	37,100	61.5	37,100	65.5	37,100	15
20	40.5	21,100	51.5	21,100	57.5	21,100	20
25	20.5	13,900	40.0	13,900	48.0	13,900	25
30			24.5	9,900	37.5	9,900	30
35					22.5	7,400	35
40							40
Zero Angle Capacity		6,900		4,600		3,500	Zero Angle Capacity

52 Ft. To 58 Ft. Main Boom With Manual Retracted

Load Radius In Feet	46 Ft.		52 Ft.		58 Ft.		Load Radius In Feet
	Loaded Boom Angle (Deg.)	360°	Loaded Boom Angle (Deg.)	360°	Loaded Boom Angle (Deg.)	360°	
10	76.0	47,200	78.0	46,800			10
12	73.5	47,200	76.0	43,800	77.5	40,200	12
15	69.5	37,100	72.5	37,100	74.5	34,900	15
20	62.5	21,100	66.0	21,100	69.0	21,100	20
25	55.0	13,900	59.5	13,900	63.5	13,900	25
30	46.5	9,900	53.0	9,900	57.5	9,900	30
35	37.0	7,400	45.5	7,400	51.5	7,400	35
40	24.5	5,700	37.0	5,700	44.5	5,700	40
45			26.0	4,400	36.5	4,400	45
50					27.0	3,400	50
Zero Angle Capacity		2,500		1,800		1,300	Zero Angle Capacity

Note: Refer To Page 7 For "Lifting Capacity Deductions" For Capacity Reductions Caused By Stowed Or Erected Auxillary Load Handling Equipment.

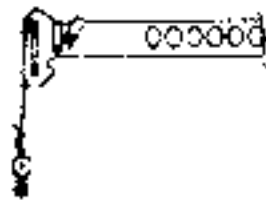

**Maximum Allowable Lifting Capacities
Rated Lifting Capacities In Pounds
On Outriggers Half Extended
See Set Up Note 2.**

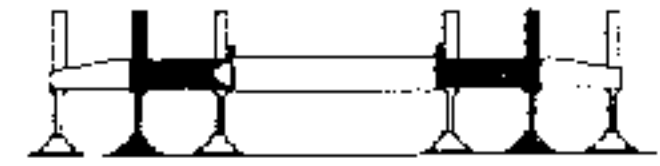

64 Ft. To 70.25 Ft. Main Boom With Manual Retracted

Load Radius In Feet	64 Ft.		70.25 Ft.		Load Radius In Feet
	Loaded Boom Angle (Deg.)	360°	Loaded Boom Angle (Deg.)	360°	
10					10
12					12
15	76.5	32,100	78.0	28,500	15
20	71.5	21,100	74.0	21,100	20
25	66.5	13,900	69.0	13,900	25
30	61.5	9,900	64.5	9,900	30
35	56.0	7,400	59.5	7,400	35
40	50.0	5,700	54.5	5,700	40
45	44.0	4,400	49.5	4,400	45
50	36.5	3,400	43.5	3,400	50
55	28.0	2,600	37.0	2,600	55
60	15.0	1,900	29.0	1,900	60
65			18.5	1,400	65
Zero Angle Capacity		900	Minimum Boom Angle Degree For No Load: 18.5°		Zero Angle Capacity

Note: Refer To Page 7 For "Lifting Capacity Deductions" For Capacity Reductions Caused By Stowed Or Erected Auxillary Load Handling Equipment.

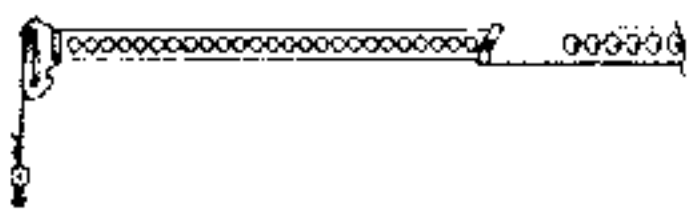

**Maximum Allowable Lifting Capacities
Rated Lifting Capacities In Pounds
On Outriggers Half Extended
See Set Up Note 2.**

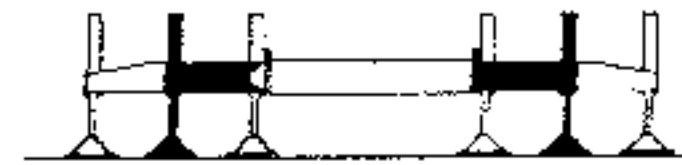

91 Ft. Main Boom With Manual Extended

Load Radius In Feet	91 Ft.		Load Radius In Feet
	Loaded Boom Angle (Deg.)	360°	
20	79.0	18,600	20
25	75.5	15,000	25
30	72.0	10,900	30
35	68.5	8,400	35
40	64.5	6,500	40
45	61.0	5,200	45
50	57.0	4,200	50
55	53.0	3,400	55
60	49.0	2,700	60
65	44.5	2,100	65
70	39.5	1,700	70
75	34.0	1,300	75
Minimum Boom Angle For No Load: 34°			Minimum Boom Angle For No Load: 34°

Note: Refer To Page 7 For "Lifting Capacity Deductions" For Capacity Reductions Caused By Stowed Or Erected Auxillary Load Handling Equipment.

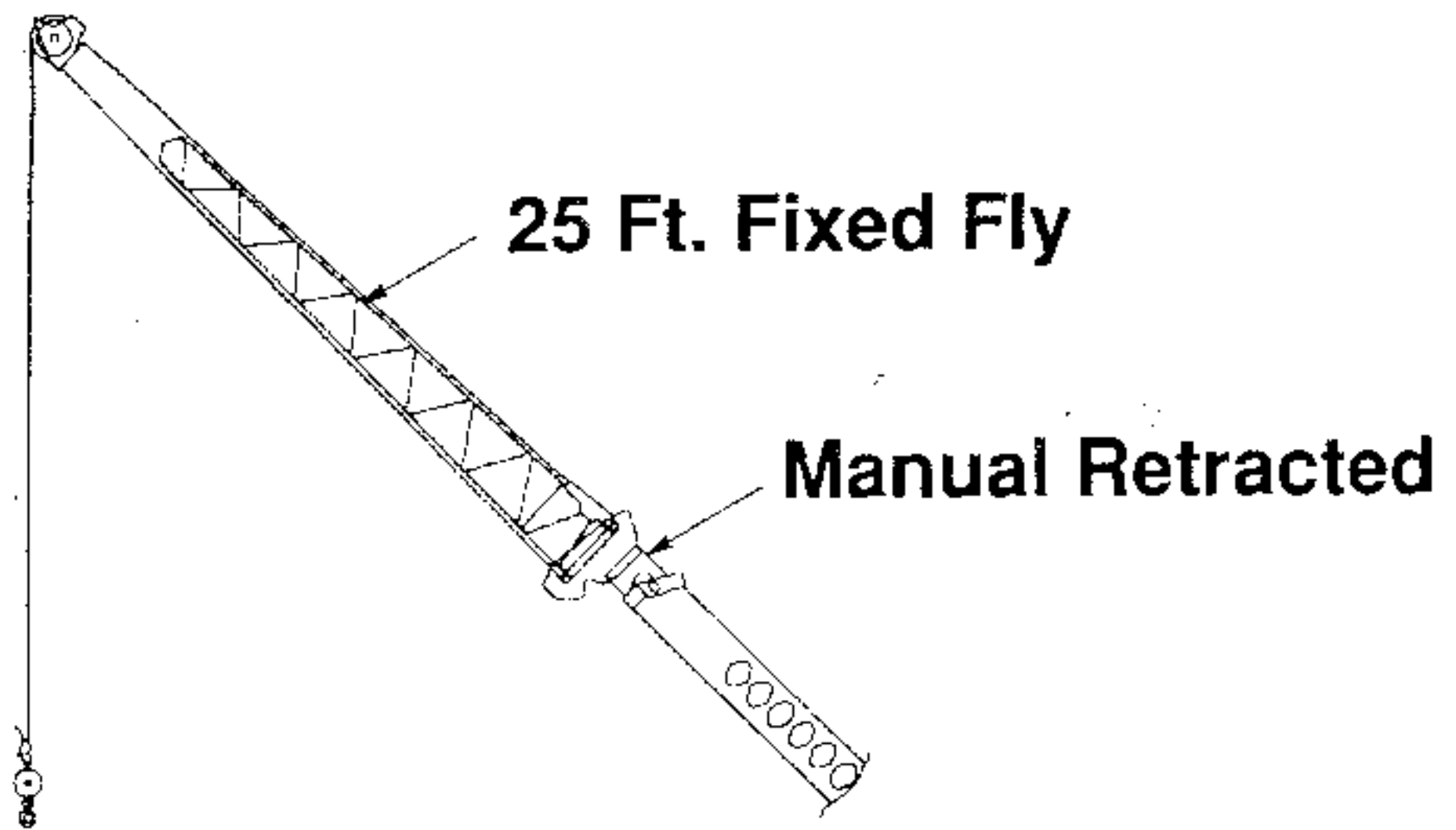

Maximum Allowable Lifting Capacities Rated Lifting Capacities In Pounds On Outriggers Half Extended See Set Up Note 2.			
70.25 Ft. Main Boom Manual Retracted + 25 Ft. Fixed Fly			
Load Radius In Feet	95.25 Ft.		Load Radius In Feet
	Loaded Boom Angle (Deg.)	360°	
20	78.5	16,200	20
25	75.5	13,900	25
30	72.5	11,000	30
35	69.0	8,500	35
40	65.5	6,600	40
45	62.0	5,300	45
50	58.0	4,300	50
55	54.5	3,500	55
60	50.5	2,800	60
65	46.0	2,200	65
70	41.5	1,800	70
75	37.0	1,400	75
80	31.0	1,100	80



WARNING

Do Not Lower 25 Ft. Fixed Fly In Working Position Below 31 Degrees Unless Main Boom Length Is 59 Ft. Or Less, Since Loss Of Stability Will Occur Causing A Tipping Condition.

Note: Refer To Page 7 For "Lifting Capacity Deductions" For Capacity Reductions Caused By Stowed Or Erected Auxillary Load Handling Equipment.

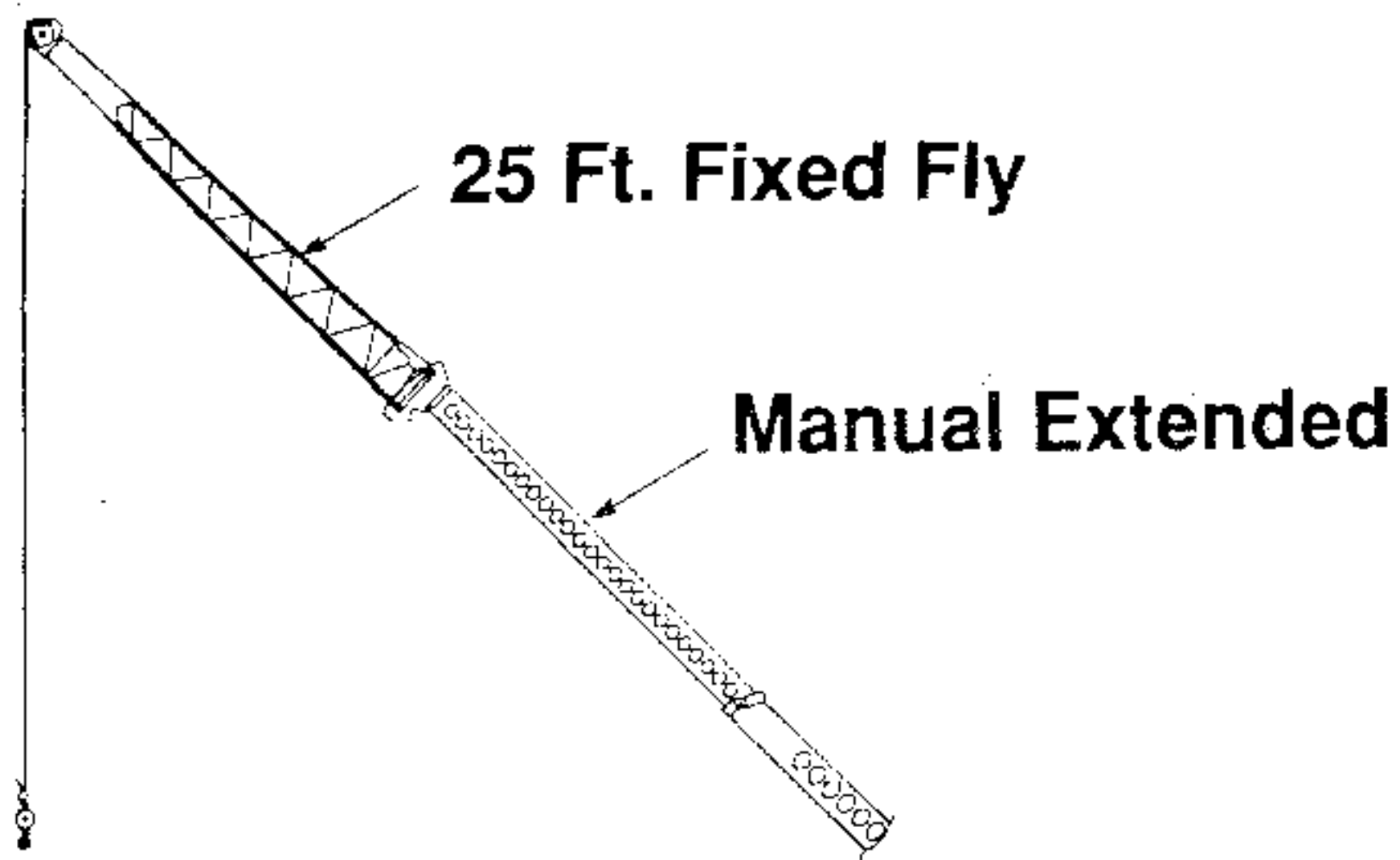

Maximum Allowable Lifting Capacities Rated Lifting Capacities In Pounds On Outriggers Half Extended See Set Up Note 2.			
91 Ft. Main Boom Manual Extended + 25 Ft. Fixed Fly			
Load Radius In Feet	116 Ft.		Load Radius In Feet
	Loaded Boom Angle (Deg.)	360°	
30	77.5	10,300	30
35	74.5	8,800	35
40	72.0	7,000	40
45	69.0	5,700	45
50	66.0	4,600	50
55	63.0	3,800	55
60	60.0	3,100	60
65	57.0	2,600	65
70	54.0	2,100	70
75	50.5	1,700	75
80	47.0	1,400	80
85	43.5	1,100	85



WARNING

Do Not Lower 25 Ft. Fixed Fly In Working Position Below 43 Degrees Unless Main Boom Length Is 69 Ft. Or Less, Since Loss Of Stability Will Occur Causing A Tipping Condition.

Note: Refer To Page 7 For "Lifting Capacity Deductions" For Capacity Reductions Caused By Stowed Or Erected Auxillary Load Handling Equipment.

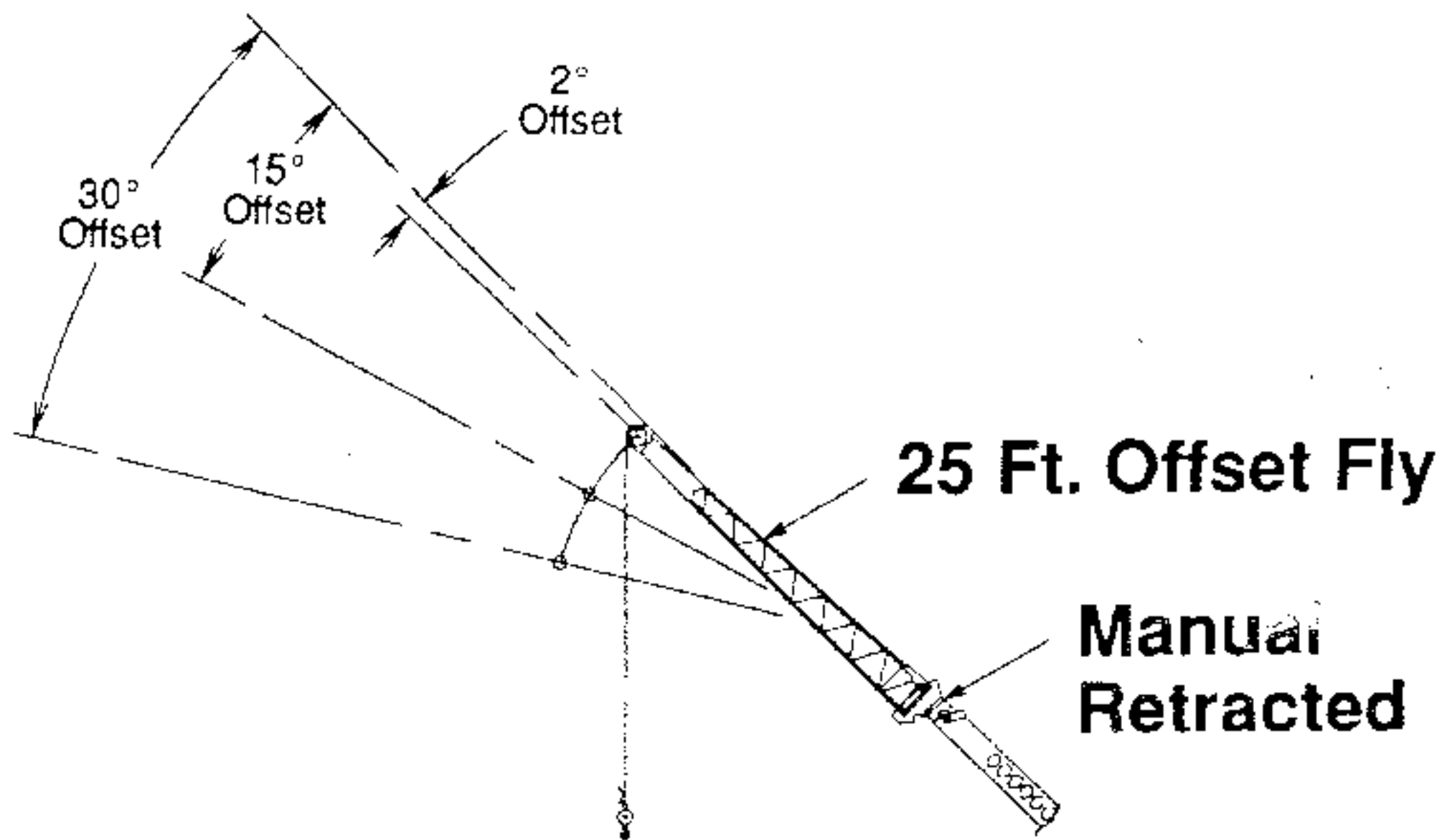

Maximum Allowable Lifting Capacities Rated Lifting Capacities In Pounds On Outriggers Half Extended See Set Up Note 2.							
70.25 Ft. Main Boom Manual Retracted + 25 Ft. Offset Fly							
Load Radius In Feet	2° Offset		15° Offset		30° Offset		Load Radius In Feet
	Loaded Boom Angle (Deg.)	360°	Loaded Boom Angle (Deg.)	360°	Loaded Boom Angle (Deg.)	360°	
20	78.5	13,000					20
25	75.5	11,900	79.0	9,100			25
30	72.5	10,800	76.0	8,500	79.0	6,400	30
35	69.0	8,300	73.0	7,800	76.0	6,000	35
40	65.5	6,400	69.5	6,900	72.5	5,700	40
45	62.0	5,100	66.0	5,500	69.5	5,400	45
50	58.5	4,000	62.0	4,400	65.5	4,700	50
55	55.0	3,200	58.5	3,500	61.5	3,800	55
60	51.0	2,500	54.5	2,800	57.5	3,000	60
65	47.0	2,000	50.0	2,200	53.0	2,400	65
70	42.5	1,500	45.5	1,700	48.0	1,800	70
75	37.5	1,100	40.5	1,300	43.0	1,300	75
80					37.0	1,000	80



WARNING

Do Not Lower 25 Ft. Offset Fly in Working Position Below 37 Degrees Unless Main Boom Length Is 55 Ft. Or Less, Since Loss Of Stability Will Occur Causing A Tipping Condition.

Note: Refer To Page 7 For "Lifting Capacity Deductions" For Capacity Reductions Caused By Stowed Or Erected Auxillary Load Handling Equipment.

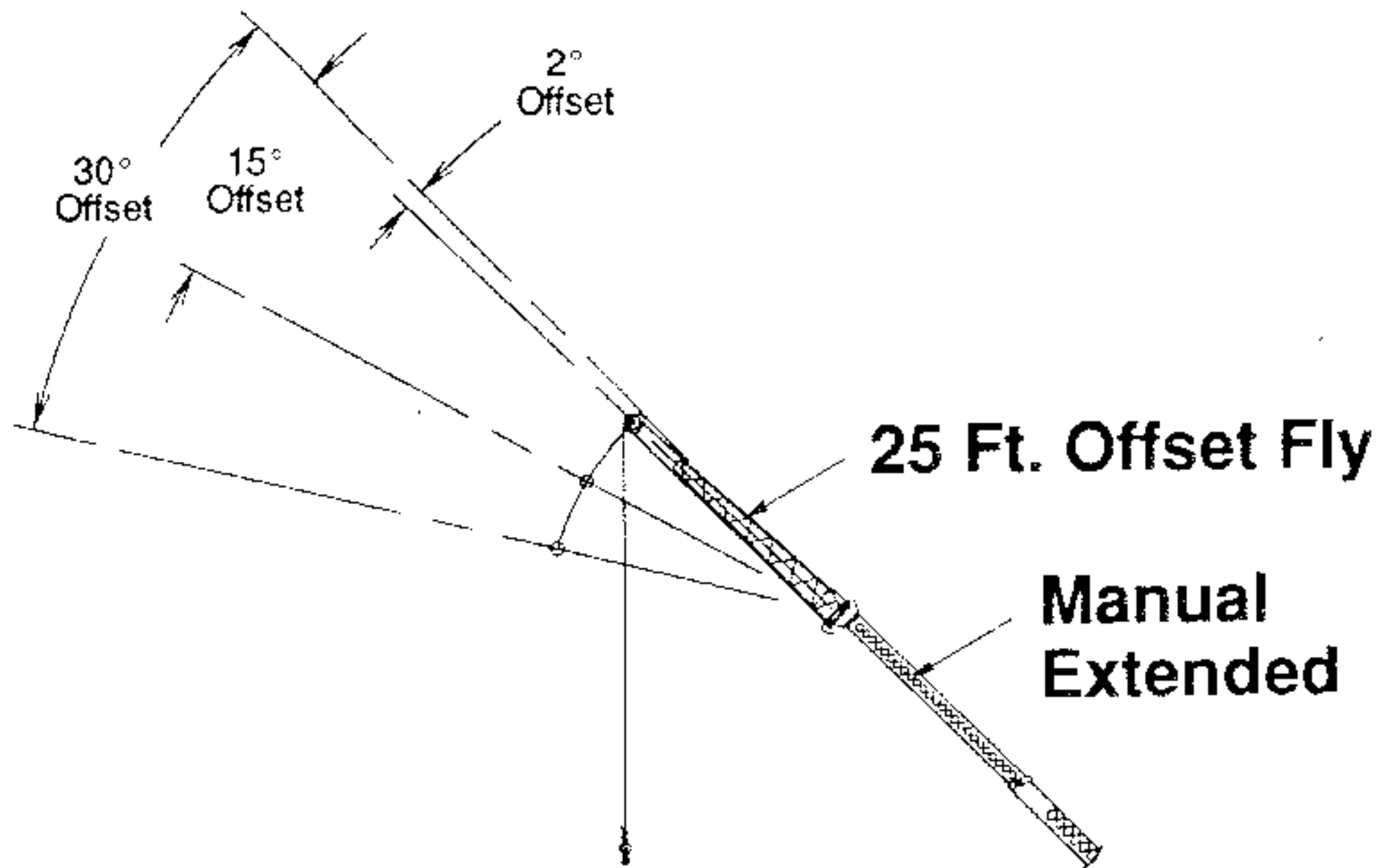

Maximum Allowable Lifting Capacities Rated Lifting Capacities In Pounds On Outriggers Half Extended See Set Up Note 2.							
91 Ft. Main Boom Manual Extended + 25 Ft. Offset Fly							
Load Radius In Feet	2° Offset		15° Offset		30° Offset		Load Radius In Feet
	Loaded Boom Angle (Deg.)	360°	Loaded Boom Angle (Deg.)	360°	Loaded Boom Angle (Deg.)	360°	
25	79.5	10,300					25
30	77.0	9,100	80.0	8,400			30
35	75.0	8,100	77.5	7,400	80.0	6,400	35
40	72.5	6,800	75.0	6,600	77.5	5,900	40
45	70.0	5,400	72.5	5,800	75.0	5,300	45
50	67.0	4,400	70.0	4,700	72.5	4,900	50
55	64.0	3,500	67.0	3,800	69.5	4,100	55
60	61.0	2,900	64.0	3,100	66.5	3,400	60
65	58.0	2,300	61.0	2,500	63.5	2,800	65
70	54.5	1,800	57.5	2,000	60.5	2,200	70
75	51.5	1,400	54.5	1,600	57.0	1,800	75
80	48.0	1,100	50.5	1,200	53.0	1,400	80
85	44.0	800	47.0	900	49.0	1,000	85

WARNING

Do Not Lower 25 Ft. Offset Fly In Working Position Below 47 Degrees Unless Main Boom Length Is 65 Ft. Or Less, Since Loss Of Stability Will Occur Causing A Tipping Condition.

Note: Refer To Page 7 For "Lifting Capacity Deductions" For Capacity Reductions Caused By Stowed Or Erected Auxilliary Load Handling Equipment.

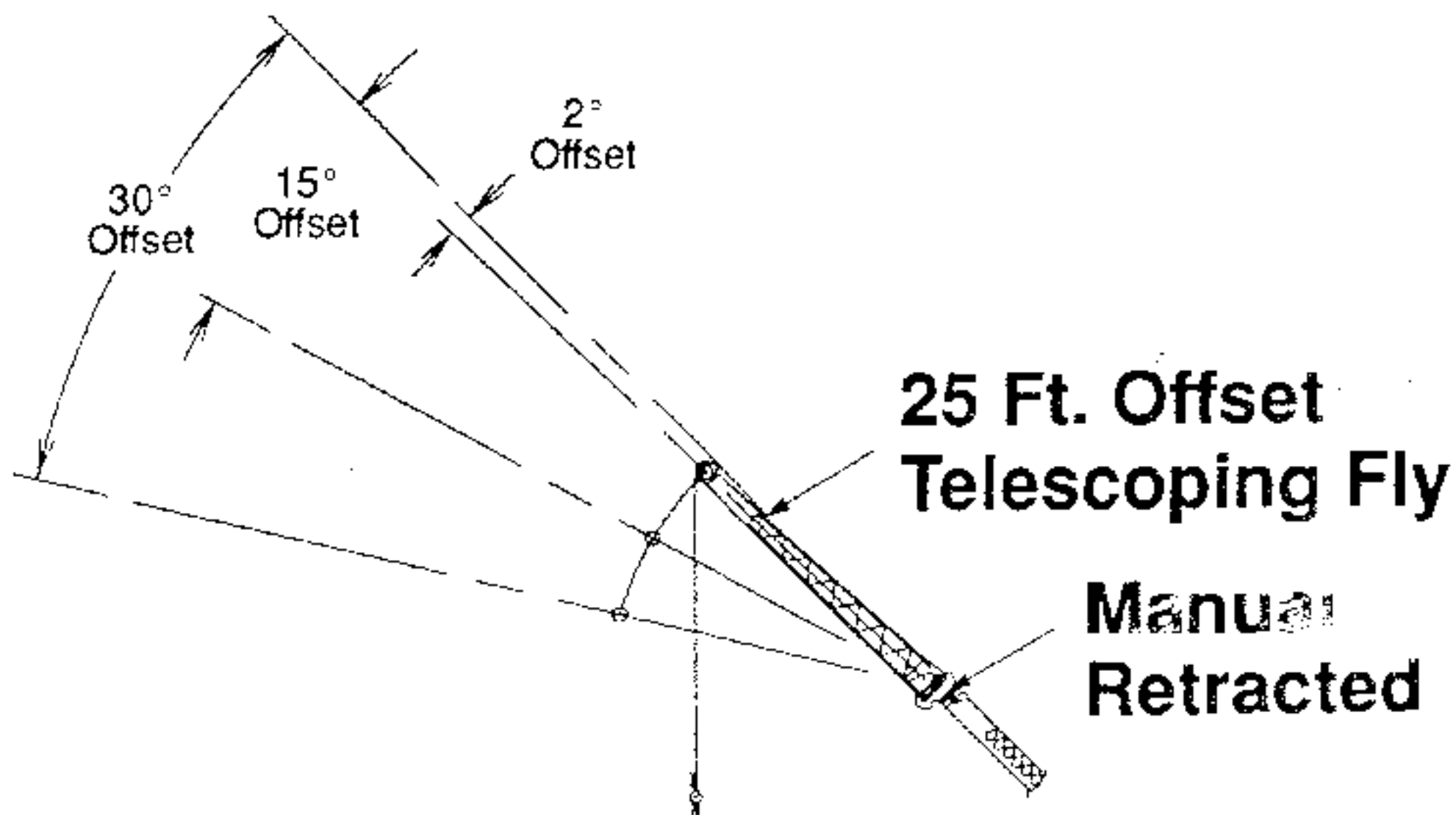

Maximum Allowable Lifting Capacities Rated Lifting Capacities In Pounds On Outriggers Half Extended See Set Up Note 2.							
70.25 Ft. Main Boom Manual Retracted + 25 Ft. Offset Telescoping Fly							
Load Radius In Feet	25 Ft.						Load Radius In Feet
	2° Offset		15° Offset		30° Offset		
	Loaded Boom Angle (Deg.)	360°	Loaded Boom Angle (Deg.)	360°	Loaded Boom Angle (Deg.)	360°	
20	78.5	12,700					20
25	75.5	11,500	79.0	8,800			25
30	72.5	10,500	76.0	8,200	79.0	6,100	30
35	69.0	8,000	73.0	7,500	76.0	5,700	35
40	65.5	6,100	69.5	6,600	72.5	5,400	40
45	62.5	4,800	66.0	5,200	69.0	5,100	45
50	58.5	3,700	62.0	4,100	65.5	4,500	50
55	55.0	2,900	58.5	3,200	61.5	3,500	55
60	51.0	2,200	54.5	2,500	57.5	2,700	60
65	47.0	1,700	50.0	1,900	53.0		65
70	42.5	1,200	45.5	1,400	48.0		70
75			40.5	1,000	43.0	1,100	75

! WARNING

Do Not Lower 25 Ft. Offset Telescoping Fly In Working Position Below 40 Degrees Unless Main Boom Length Is 51 Ft. Or Less, Since Loss Of Stability Will Occur Causing A Tipping Condition.

Note: Refer To Page 7 For "Lifting Capacity Deductions" For Capacity Reductions Caused By Stowed Or Erected Auxillary Load Handling Equipment.

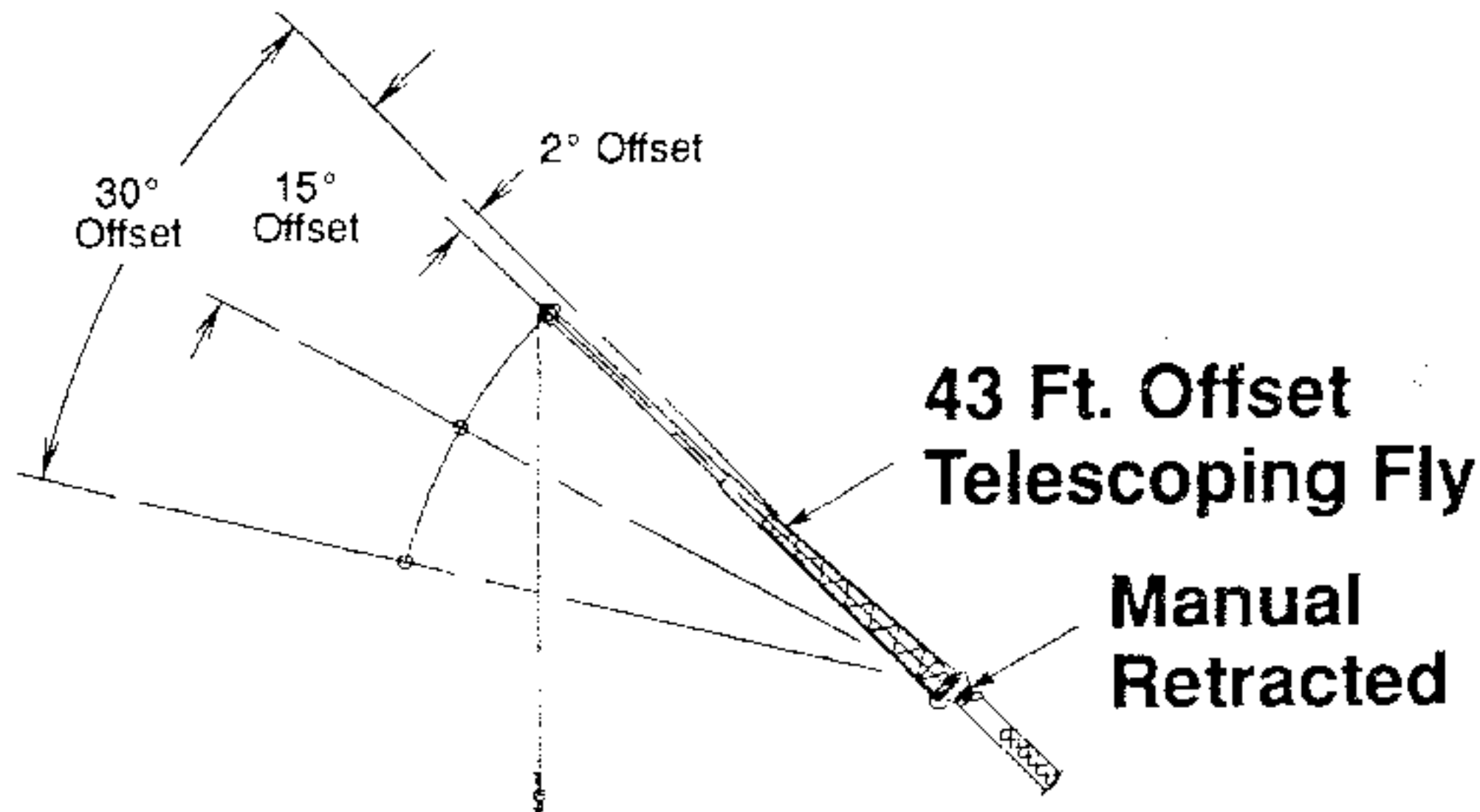

Maximum Allowable Lifting Capacities Rated Lifting Capacities In Pounds On Outriggers Half Extended See Set Up Note 2.							
70.25 Ft. Main Boom Manual Retracted + 43 Ft. Offset Telescoping Fly							
Load Radius In Feet	43 Ft.						Load Radius In Feet
	2° Offset		15° Offset		30° Offset		
	Loaded Boom Angle (Deg.)	360°	Loaded Boom Angle (Deg.)	360°	Loaded Boom Angle (Deg.)	360°	
25	77.5	4,900					25
30	75.5	4,700					30
35	73.0	4,500	78.0	4,000			35
40	70.0	4,300	75.5	3,900			40
45	67.5	4,100	72.5	3,700	77.5	3,000	45
50	65.0	3,900	70.0	3,500	74.5	2,900	50
55	62.0	3,600	67.0	3,300	71.5	2,700	55
60	59.0	2,900	64.0	3,100	68.5	2,600	60
65	56.0	2,400	61.0	2,800	65.5	2,500	65
70	52.5	1,900	57.5	2,200	62.5	2,400	70
75	49.5	1,500	54.0	1,800	58.5	2,100	75
80	45.5	1,100	50.5	1,400	55.0	1,600	80
85			46.5	1,100	50.5	1,300	85
90					46.0	900	90



WARNING

Do Not Lower 43 Ft. Offset Telescoping Fly In Working Position Below 45 Degrees Unless Main Boom Length Is 48 Ft. Or Less, Since Loss Of Stability Will Occur Causing A Tipping Condition.

Note: Refer To Page 7 For "Lifting Capacity Deductions" For Capacity Reductions Caused By Stowed Or Erected Auxilliary Load Handling Equipment.

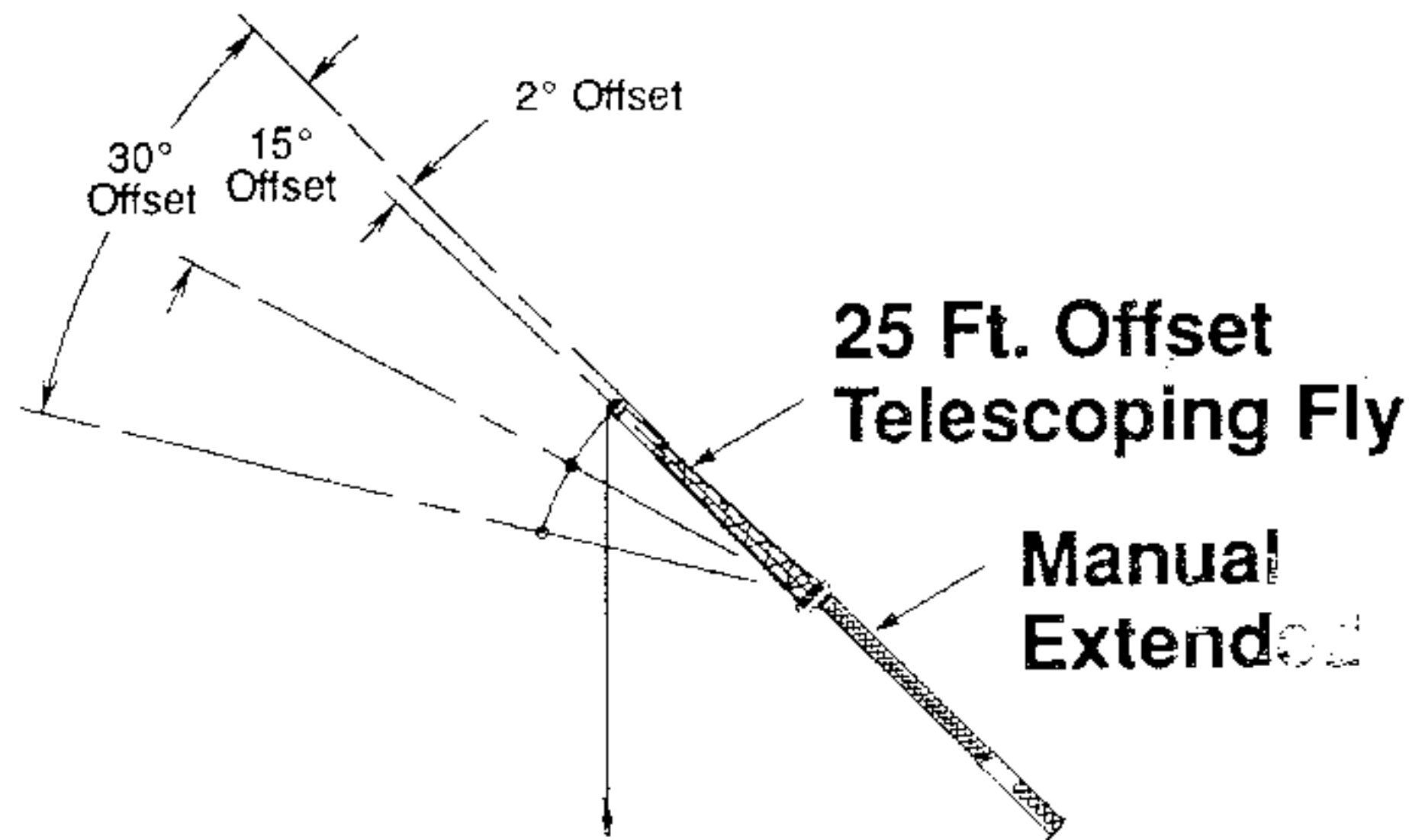

Maximum Allowable Lifting Capacities Rated Lifting Capacities In Pounds On Outriggers Half Extended See Set Up Note 2.							
91 Ft. Main Boom Manual Extended + 25 Ft. Offset Telescoping Fly							
Load Radius In Feet	25 Ft.						Load Radius In Feet
	2° Offset		15° Offset		30° Offset		
	Loaded Boom Angle (Deg.)	360°	Loaded Boom Angle (Deg.)	360°	Loaded Boom Angle (Deg.)	360°	
25	79.5	9,900					25
30	77.0	8,700	80.0	8,000			30
35	75.0	7,700	77.5	7,000	80.0	6,000	35
40	72.5	6,500	75.0	6,200	77.5	5,500	40
45	70.0	5,100	72.5	5,500	75.0	5,000	45
50	67.0	4,000	70.0	4,400	72.5	4,500	50
55	64.0	3,200	67.0	3,500	69.5	3,800	55
60	61.0	2,500	64.0	2,800	66.5	3,100	60
65	58.0	2,000	61.0	2,200	63.5	2,500	65
70	54.5	1,500	57.5	1,700	60.5		70
75	51.5	1,100	54.5	1,300	57.0		75
80			50.5	900	53.0	1,100	80

! WARNING

Do Not Lower 25 Ft. Offset Telescoping Fly In Working Position Below 50 Degrees Unless Main Boom Length Is 60 Ft. Or Less, Since Loss Of Stability Will Occur Causing A Tipping Condition.

Note: Refer To Page 7 For "Lifting Capacity Deductions" For Capacity Reductions Caused By Stowed Or Erected Auxillary Load Handling Equipment.

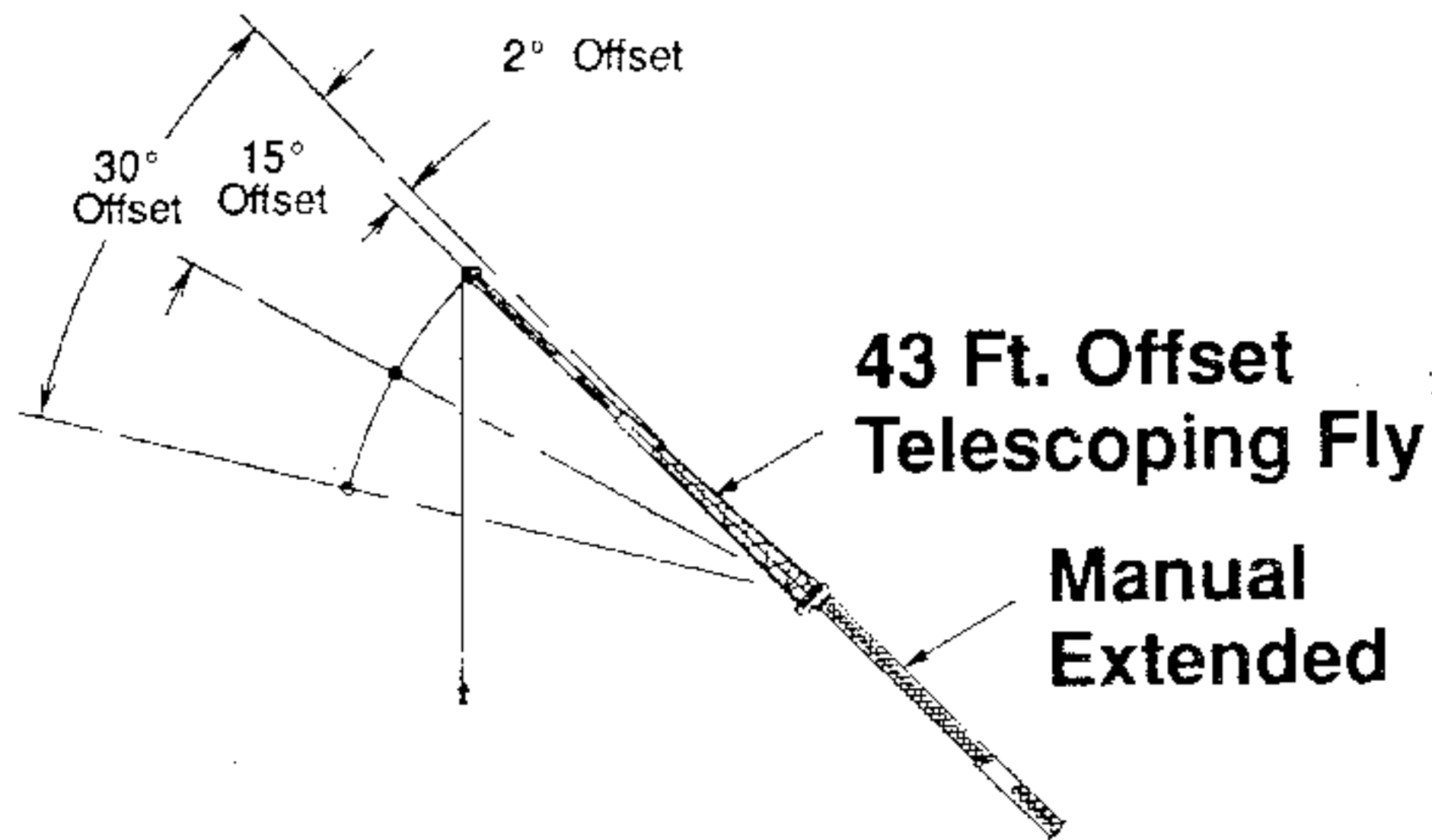

Maximum Allowable Lifting Capacities Rated Lifting Capacities In Pounds On Outriggers Half Extended See Set Up Note 2.							
91 Ft. Main Boom Manual Extended + 43 Ft. Offset Telescoping Fly							
Load Radius In Feet	43 Ft.						Load Radius In Feet
	2° Offset		15° Offset		30° Offset		
	Loaded Boom Angle (Deg.)	360°	Loaded Boom Angle (Deg.)	360°	Loaded Boom Angle (Deg.)	360°	
35	78.0	4,900					35
40	75.5	4,700	79.0	4,000			40
45	73.5	4,500	77.5	3,900			45
50	71.5	4,300	75.5	3,700	79.0	3,100	50
55	69.0	3,800	73.0	3,400	77.0	3,000	55
60	66.5	3,100	70.5	3,100	74.5	2,800	60
65	64.5	2,500	68.0	2,800	72.0	2,600	65
70	61.5	2,000	65.5	2,400	69.5	2,400	70
75	59.0	1,600	63.0	2,000	66.5	2,200	75
80	56.0	1,300	60.5	1,600	64.0	1,900	80
85	53.5	1,000	58.0	1,200	61.0	1,500	85
90			54.5	900	58.0	1,200	90
95					54.5	900	95



WARNING

Do Not Lower 43 Ft. Offset Telescoping Fly In Working Position Below 52 Degrees Unless Main Boom Length Is 57 Ft. Or Less, Since Loss Of Stability Will Occur Causing A Tipping Condition.

Note: Refer To Page 7 For "Lifting Capacity Deductions" For Capacity Reductions Caused By Stowed Or Erected Auxillary Load Handling Equipment.

WORKING RANGE DIAGRAM

Working Range Diagram
On Outriggers Fully Retracted

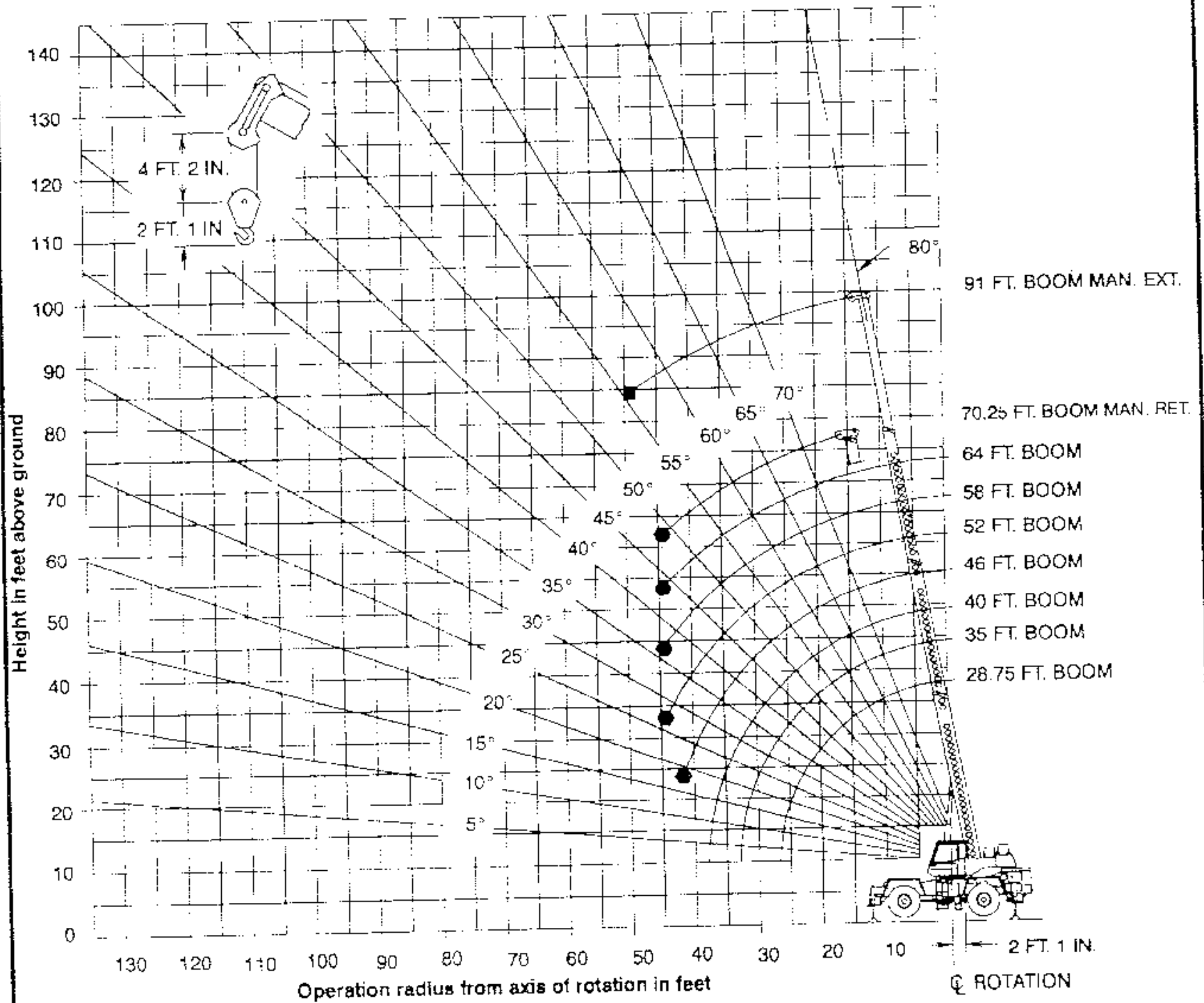
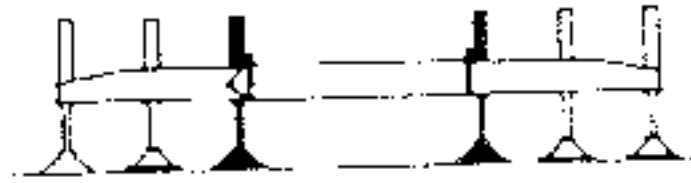

- Denotes Main Boom With Manual Retracted Minimum Boom Angle For No Load.
- Denotes 91 Ft. Main Boom With Manual Extended Minimum Boom Angle For No Load.

* Note: Boom geometry shown is for unloaded condition and crane standing level on firm supporting surface. Boom deflection, subsequent radius and boom angle change must be accounted for when applying load to hook.



WARNING

Do Not Lower The Boom Below The Minimum Boom Angle For No Load As Shown In The Above Chart For The Boom Lengths Shown. Loss Of Stability Will Occur Causing A Tipping Condition.

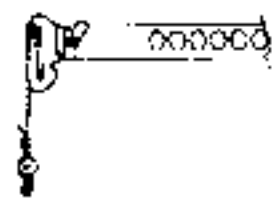

**Maximum Allowable Lifting Capacities
Rated Lifting Capacities in Pounds
On Outriggers Fully Retracted
See Set Up Note 2.**



28.75 Ft. To 40 Ft. Main Boom With Manual Retracted

Load Radius In Feet	28.75 Ft.		35 Ft.		40 Ft.		Load Radius In Feet
	Loaded Boom Angle (Deg.)	360°	Loaded Boom Angle (Deg.)	360°	Loaded Boom Angle (Deg.)	360°	
10	66.0	34,100	70.5	34,100	73.0	34,100	10
12	61.5	24,300	67.0	24,300	70.0	24,300	12
15	54.0	16,400	61.5	16,400	65.5	16,400	15
20	40.5	9,800	51.5	9,800	57.0	9,800	20
25	20.5	6,400	40.0	6,400	48.0	6,400	25
30			24.0	4,300	37.5	4,300	30
35					22.5	2,900	35
Zero Angle Capacity		3,200		1,900		1,200	Zero Angle Capacity

46 Ft. To 50 Ft. Main Boom With Manual Retracted

Load Radius In Feet	46 Ft.		52 Ft.		58 Ft.		Load Radius In Feet
	Loaded Boom Angle (Deg.)	360°	Loaded Boom Angle (Deg.)	360°	Loaded Boom Angle (Deg.)	360°	
10	75.5	34,000	77.5	34,000			10
12	73.0	24,300	75.5	24,300	77.0	24,300	12
15	69.0	16,400	71.5	16,400	74.0	16,400	15
20	62.0	9,800	65.5	9,800	68.5	9,800	20
25	54.5	6,400	59.5	6,400	63.0	6,400	25
30	46.5	4,300	52.5	4,300	57.0	4,300	30
35	37.0	2,900	45.0	2,900	51.0	2,900	35
40	24.5	2,000	36.5	2,000	44.0	2,000	40
45			26.0	1,200	36.5	1,200	45
Min. Boom Angle For No Load:	17°		26°		36°		Min. Boom Angle For No Load:

Note: Refer To Page 7 For "Lifting Capacity Deductions" For Capacity Reductions Caused By Stowed Or Erected Auxilliary Load Handling Equipment.

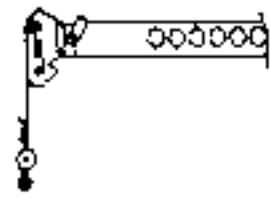

**Maximum Allowable Lifting Capacities
Rated Lifting Capacities in Pounds
On Outriggers Fully Retracted
See Set Up Note 2.**

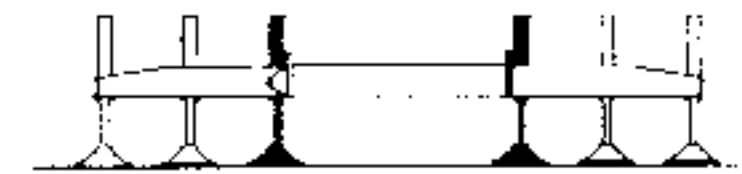

64 Ft. To 70.25 Ft. Main Boom With Manual Retracted					
Load Radius In Feet	64 Ft.		70.25 Ft.		Load Radius In Feet
	Loaded Boom Angle (Deg.)	360°	Loaded Boom Angle (Deg.)	360°	
10					10
12					12
15	75.5	16,400	77.5	16,400	15
20	71.0	9,800	73.0	9,800	20
25	66.0	6,400	68.5	6,400	25
30	61.0	4,300	64.0	4,300	30
35	55.5	2,900	59.0	2,900	35
40	49.5	2,000	54.0	2,000	40
45	43.5	1,200	49.0	1,200	45
Min. Boom Angle For No Load:	43.5°		49°		Min. Boom Angle For No Load:

Note: Refer To Page 7 For "Lifting Capacity Deductions" For Capacity Reductions Caused By Stowed Or Erected Auxillary Load Handling Equipment.

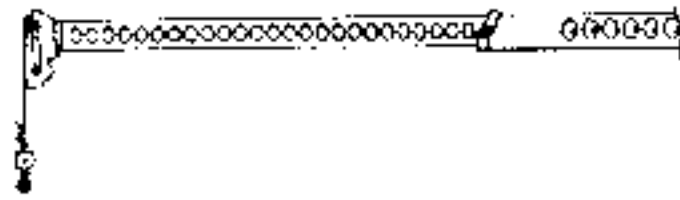

**Maximum Allowable Lifting Capacities
Rated Lifting Capacities In Pounds
On Outriggers Fully Retracted
See Set Up Note 2.**



91 Ft. Main Boom With Manual Extended

Load Radius In Feet	91 Ft.		Load Radius In Feet
	Loaded Boom Angle (Deg.)	360°	
20	78.0	10,700	20
25	74.5	7,300	25
30	71.0	5,200	30
35	67.5	3,800	35
40	64.0	2,800	40
45	60.5	2,000	45
50	56.5	1,400	50

Minimum Boom Angle (Deg.) For No Load: 56°

Note: Refer To Page 7 For "Lifting Capacity Deductions" For Capacity Reductions Caused By Stowed Or Erected Auxillary Load Handling Equipment.

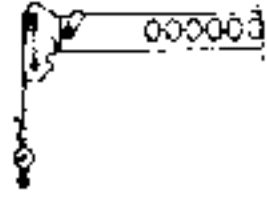

On Tire Capacities In Pounds With 20.5x25 Tires
Tire Pressure: 80 PSI
Stationary Capacities – Between Tire Tracks Over Front
See Operation Note 19.



Load Radius In Feet	28.75 Ft. to 46 Ft. Main Boom								Load Radius In Feet
	28.75 Ft.		35 Ft.		40 Ft.		46 Ft.		
	Loaded Boom Angle (Deg.)	Load	Loaded Boom Angle (Deg.)	Load	Loaded Boom Angle (Deg.)	Load	Loaded Boom Angle (Deg.)	Load	
10	66.0	35,900	70.5	35,900	73.5	35,800			10
12	61.5	31,600	67.0	31,500	70.5	31,500	73.5	31,400	12
15	54.5	26,600	61.5	26,500	66.0	26,500	69.5	26,500	15
20	40.5	20,500	52.0	20,500	57.5	20,500	62.5	20,500	20
25	20.5	15,600	40.0	15,600	48.5	15,600	55.0	15,600	25
30			24.5	11,200	37.5	11,200	47.0	11,200	30
35					23.0	8,400	37.5	8,400	35
40							25.0	6,500	40

Minimum Boom Angle For No Load: 0°

Load Radius In Feet	52 Ft. to 70.25 Ft. Main Boom								Load Radius In Feet
	52 Ft.		58 Ft.		64 Ft.		70.25 Ft.		
	Loaded Boom Angle (Deg.)	Load	Loaded Boom Angle (Deg.)	Load	Loaded Boom Angle (Deg.)	Load	Loaded Boom Angle (Deg.)	Load	
15	72.5	26,500							15
20	66.5	20,500	69.5	20,500					20
25	60.0	15,600	64.0	15,600	67.0	15,600	70.0	15,600	25
30	53.5	11,200	58.0	11,200	62.0	11,200	65.5	11,200	30
35	46.0	8,400	52.0	8,400	56.5	8,400	60.5	8,400	35
40	37.5	6,500	45.0	6,500	51.0	6,500	55.5	6,500	40
45	26.5	5,100	37.5	5,100	44.5	5,100	50.0	5,100	45
50			27.5	4,000	37.5	4,000	44.5	4,000	50
55					28.5	3,100	37.5	3,100	55
60					16.0	2,400	30.0	2,400	60
65							19.5	1,800	65

Minimum Boom Angle For No Load: 0°

Note: Refer To Page 7 For "Lifting Capacity Deductions" For Capacity Reductions Caused By Stowed Or Erected Auxilliary Load Handling Equipment.

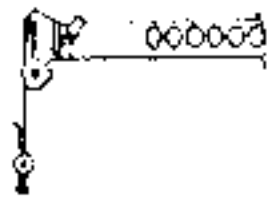

On Tire Capacities In Pounds With 20.5x25 Tires
Tire Pressure (0-1 MPH): 80 PSI
Pick & Carry Capacities - (Creep) Boom Centered Over Front
See Operation Note 19.





Load Radius In Feet	28.75 Ft. to 46 Ft. Main Boom								Load Radius In Feet
	28.75 Ft.		35 Ft.		40 Ft.		46 Ft.		
	Loaded Boom Angle (Deg.)	Load	Loaded Boom Angle (Deg.)	Load	Loaded Boom Angle (Deg.)	Load	Loaded Boom Angle (Deg.)	Load	
10	66.0	34,800	70.5	34,700					10
12	61.5	30,000	67.0	30,000	70.5	29,900			12
15	54.5	24,700	61.5	24,700	66.0	24,700	69.5	24,600	15
20	40.5	18,600	52.0	18,600	57.5	18,600	62.5	18,600	20
25	20.5	14,400	40.0	14,400	48.5	14,400	55.0	14,400	25
30			24.5	11,200	37.5	11,200	47.0	11,200	30
35					23.0	8,400	37.5	8,400	35
40							25.0	6,500	40

Minimum Boom Angle For No Load: 0°

Load Radius In Feet	52 Ft. to 70.25 Ft. Main Boom								Load Radius In Feet
	52 Ft.		58 Ft.		64 Ft.		70.25 Ft.		
	Loaded Boom Angle (Deg.)	Load	Loaded Boom Angle (Deg.)	Load	Loaded Boom Angle (Deg.)	Load	Loaded Boom Angle (Deg.)	Load	
20	66.5	18,600	69.5	18,600					20
25	60.0	14,400	64.0	14,400	67.0	14,400			25
30	53.5	11,200	58.0	11,200	62.0	11,200	65.5	11,200	30
35	46.0	8,400	52.0	8,400	56.5	8,400	60.5	8,400	35
40	37.5	6,500	45.0	6,500	51.0	6,500	55.5	6,500	40
45	26.5	5,100	37.5	5,100	44.5	5,100	50.0	5,100	45
50			27.5	4,000	37.5	4,000	44.5	4,000	50
55					28.5	3,100	37.5	3,100	55
60					16.0	2,400	30.0	2,400	60
65							19.5	1,800	65

Minimum Boom Angle For No Load: 0°

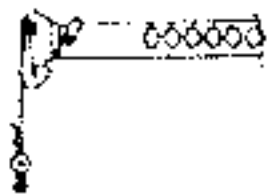
Note: Refer To Page 7 For "Lifting Capacity Deductions" For Capacity Reductions Caused By Stowed Or Erected Auxillary Load Handling Equipment.

 On Tire Capacities In Pounds With 20.5x25 Tires Tire Pressure: 80 PSI Stationary Capacities – 360 Degree See Operation Note 19. 									
Load Radius	28.75 Ft. to 46 Ft. Main Boom								Load Radius
	28.75 Ft.		35 Ft.		40 Ft.		46 Ft.		
In Feet	Loaded Boom Angle (Deg.)	Load	Loaded Boom Angle (Deg.)	Load	Loaded Boom Angle (Deg.)	Load	Loaded Boom Angle (Deg.)	Load	In Feet
10	66.0	19,000	70.5	19,000	73.5	18,900			10
12	61.5	15,800	67.0	15,800	70.5	15,800	73.5	15,800	12
15	54.5	12,300	61.5	12,300	66.0	12,300	69.5	12,300	15
20	40.5	8,400	52.0	8,400	57.5	8,400	62.5	8,400	20
25	20.5	5,400	40.0	5,400	48.5	5,400	55.0	5,400	25
30			24.5	3,600	37.5	3,600	47.0	3,600	30
35					23.0	2,300	37.5	2,300	35
40							25.0	1,400	40
Min. Boom Angle For No Load:	0°		0°		0°		25°		Min. Boom Angle For No Load:

Load Radius	52 Ft. to 70.25 Ft. Main Boom								Load Radius
	52 Ft.		58 Ft.		64 Ft.		70.25 Ft.		
In Feet	Loaded Boom Angle (Deg.)	Load	Loaded Boom Angle (Deg.)	Load	Loaded Boom Angle (Deg.)	Load	Loaded Boom Angle (Deg.)	Load	In Feet
15	72.5	12,300							15
20	66.5	8,400	69.5	8,400					20
25	60.0	5,400	64.0	5,400	67.0	5,400	70.0	5,400	25
30	53.5	3,600	58.0	3,600	62.0	3,600	65.5	3,600	30
35	46.0	2,300	52.0	2,300	56.5	2,300	60.5	2,300	35
40	37.5	1,400	45.0	1,400	51.0	1,400	55.5	1,400	40
Min. Boom Angle For No Load:	37°		45°		50°		55°		Min. Boom Angle For No Load:

Note: Refer To Page 7 For "Lifting Capacity Deductions" For Capacity Reductions Caused By Stowed Or Erected Auxillary Load Handling Equipment.

Patents

This crane is covered by one or more of the following patents:

United States:

4,011,699	4,016,688	4,380,244
4,398,698	4,431,109	4,434,902
	4,491,229	

Canada

Patented Brevete:

1,024,471 (1978)

1,045,586 (1979)

Mexico

Patentado:

141,976

142,085

Italy

Brevettato:

1,053,941